

Technical Details

1.1 Design

Elektror low pressure blowers of the ND range are radial ventilators with impellers made from galvanized sheet steel, the blades of which are curved into direction of rotation. They are directly driven by asynchronous squirrel cage motors of the company's own make, especially adapted to the blower requirements and amply dimensioned.

The attractively shaped, stream-line aluminium-cast housings as well as the dynamically balanced impellers ensure vibration-free operation at low noise levels.

The solid design of the Elektror low pressure blowers is basic for long-life operation and low operating cost.

All drive motors are manufactured to enclosure IP 54 and in accordance with VDE 0530 (IEC 34-1). As a standard the motors are laid out for a voltage of 230/400 V or 400 V Δ at 50 Hz mains frequency three-phase AC and for 230 V 50 Hz single-phase AC in accordance with IEC 38. On demand the motors for 60 Hz. mains frequency can also be supplied to IEC 38.

1.2 Performance

Ventilators are flow-generating appliances for conveying air and other gases. As for the radial blowers, the conveyed medium is drawn in axially, accelerated radially by the rotation of the impeller and expelled tangentially. The resistance to the discharged air (by duct work, pipes, filters and other parts of the installed system) has to be compensated by the generated excess pressure of the ventilator. The ability of the ventilator to generate pressure diminishes with increasing flow volume (volumetric flow rate). This operating behaviour depends on the characteristic curves of pressure difference and volumetric flow rate (specific ventilator curves).

The resistance of air-conditioning systems (system resistance) varies (in most cases) by the square of the changing volumetric flow rate, i.e.: If the flow volume is to be doubled, four times the system's resistance has to be compensated. The resulting characteristic curves are termed resistance parabolas or characteristic system curves.

The operating point of the ventilator is determined by the intersection of the two characteristic curves.

As far as the system resistance cannot exactly be calculated mathematically, recourse should be taken to experiment or empiric values. With increasing system resistance the flow volume decreases and the power consumption drops.

The maximum volumetric flow rate of the ventilator is determined by the intersection of the characteristic curves ΔP_t and P_{d2} (see figure 1).

Figure 1: Operating point of the ventilator

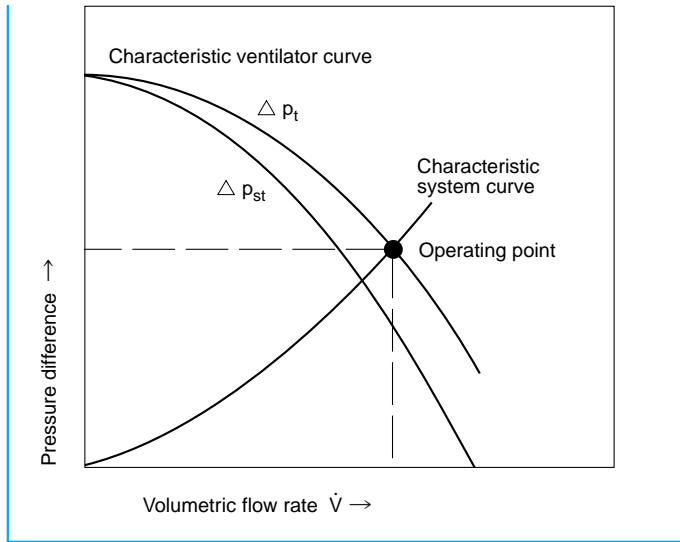

1.3 Noise characteristics

The noise caused by a ventilator ensues from flow processes and vortices inside the impeller and the housing and is determined by

- the basic design of the ventilator (axial, radial, construction principle of impeller).
- the size of the ventilator in relation to the requested pressure differentials and flow volumes.
- the operating point of the ventilator, i.e. in which range of the characteristic curve the ventilator will be operated.
- the rotational speed which can be reduced by the variable speed control for the Elektror low pressure blowers.

Noise emissions are not constant over the whole performance range.

Blower housing and impeller are especially designed for the required flow conditions, whereby the noise generation depends mainly on the required flow volume and pressure difference as well as on the correct selection of the ventilator.

For evaluation of the noise respectively of the sound pressure level the measuring unit dB(A) is used. The letter "A" in the measuring unit refers to the standardized frequency evaluation which takes into account the highly frequency-dependent and subjective perception of noise levels: High frequencies are perceived as more unpleasant than lower ones.

If a number of sound sources of equal volume are evaluated together, the sound pressure level will increase for instance by 2 dB for two appliances, by 5 dB for three, 6 dB for four, and 7 dB for five. A change by 10 dB eventually means double or half the noise level perception. With increasing distance from a sound source noise emissions grow weaker; doubling the distance may result in a noise level reduction of up to 5 dB.

1.4 Performance curves

The indicated performance curves of the total pressure head ΔP_t and of the static pressure ΔP_{st} as function of the volumetric flow rate \dot{V} have been ascertained by measuring tests and are partially above the values specified in the technical tables. The measurements were performed without protective wire mesh guard on the intake side.

All measurements were taken on a pipe test bed to DIN 24 163 with throttling on the discharge side, and based on an air density of 1,2 kg/m³.

The sound pressure levels L_A have been ascertained on the intake side at a distance of 1 m from the inlet with the blowers connected on the discharge side to the pipe test bed.

1.5 Blower selection

Applicable pressure difference

If the required pressure difference and the desired air volume have been established either by testing or by calculation, it should be verified how much of the total pressure rise of the blower can be used as static pressure difference.

If the duct work connected to the discharge side has the same cross-section as the discharge port of the blower, or if the blower discharges freely, the dynamic pressure part P_{d2} must be considered a loss. The remaining part of the total pressure rise is then available as applicable static pressure difference ΔP_{st} .

Increasing the cross-section of the discharge duct work by gradual enlargement (difusor) will delay the volume flow, and the dynamic pressure will be converted to static pressure. The recovered pressure may be included to overcome the system resistance, or allow for the use of a smaller blower at the same volumetric flow rate (see performance curve 2, figure2). The efficiency of difusors depends on the opening angle. Pressure gains by difusors on the intake side are unimportant and may be neglected.

Influence of density

Total pressure difference, dynamic pressure, static pressure and power consumption of the blower change in proportion to the density of the conveyed medium and are to be considered when selecting a blower (figure 3).

Alterations in density due to influence of temperature are calculated as follows:

$$Q_2 = Q_1 \frac{273 + \vartheta_1}{273 + \vartheta_2} \quad \begin{matrix} \vartheta = \text{temperature of conveyed medium [}^\circ\text{C]} \\ \rho = \text{air density [kg/m}^3\text{]} \end{matrix}$$

Figure 3: Influence of density of conveyed medium

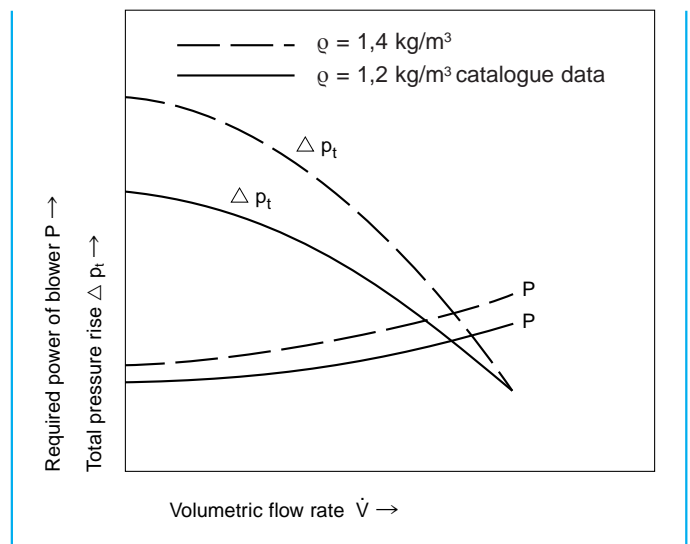
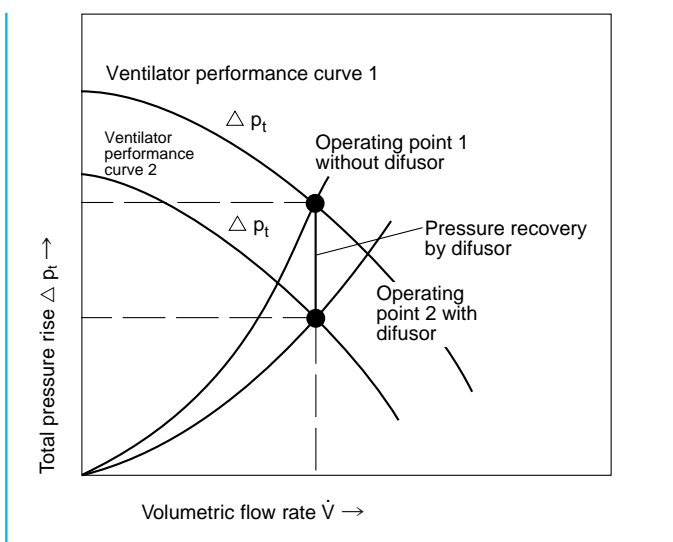

Figure 2: Pressure recovery



Fields of application

Elektror low pressure blowers offer a wide field of application facilities:

- Conveying of large air volumes at smaller and medium system resistance
- Exhausting gases and vapours
- Cooling of apparatus and machinery parts
- Ventilation of rooms
- Chimney draft boosting
- Air supply to gas-, oil- and coal-fired systems
- Drying parts of various structure
- Ventilation of electric machines

1.6 Standard and special designs

Standard range

Application is useful wherever unchanging operating conditions prevail or pressure relations vary slightly only and a constant flow volume is required.

All units of the standard range correspond to the safety requirements of the Supervisory Board of the Chemical Industry and have been tested and certified.

Twin blowers

Driven by one common motor and attached to both sides of it, two blowers are assembled into one single unit as a special construction design.

The advantage of these blowers is the high flow volume with small dimensional layout.

As the twin blowers possess two discharge connectors, the volumetric flow rates may be used together or separately for the respective applications.

Speed controlled blowers

They are to be used wherever for process-inherent reasons the change of volumetric flow is needed.

Model range RVE

By means of a generalised phase control, which is housed in the terminal box of the motor in a space-saving way, any random operating point can be continuously adjusted within a range of 20 to 100 % within the characteristic field by means of the potentiometer supplied. A two-stage setting is possible as well.

In case of speed reduction, energy is saved effectively in the partial load range, and the noise generation is reduced distinctly.

Alternating current motors speed adjustable by voltage reduction from own production are used as drives especially adapted to the ventilator. The motors have been equipped with PTC thermistors so that a thermistor-type motor protection is ensured in combination with the generalised phase control.

Thus, the user has a wide range of applications with ideal problem solution and the following advantages:

- Continuously adjustable from 20 to 100 %
- Absolutely free from maintenance
- Considerable reduction of the sound emission in case of speed reduction

Model range RS

2-step version for three phase and single phase a.c. with installed temperature controller as motor protection for which the speed-control can be effected via step switch.

Speed controlled blowers of the range RVE and RS cannot be delivered with temperature barrier. Maximum temperature of the conveyed medium is 40° C.

Model range FU

All standard blowers can be speed-controlled via frequency converter. The motors are equipped with PTC thermistor sensors for trip device and with a reinforced barrier.

The technical data are identical with those of the standard blowers. Speed control from 0 to 50 Hz maximum.

Compact blowers

The design offers very compact dimensions by incorporating the motor into the blower housing respectively into the impeller at comparatively favourable characteristic curves.

The motor needs no additional cooling as it is located in the air flow. To guarantee sufficient cooling of the motor the blower cannot be operated fully throttled – neither on the discharged side nor on the intake side.

In case of high air pollution a filter must be fitted on the intake side to avoid contamination of motor and impeller.

Special blowers

For special applications the standard blowers can be adapted to existing requirements by special equipment whereat also custom-made solutions can be found.

Conveyed medium and ambient temperatures

The permitted ambient temperature (cooling air temperature) of the drive motors is -30 °C to + 40 °C. As a standard the motors are made to thermal class B in accordance with VDE 0530 (IEC 34-1), the speed-controlled version to thermal class F.

An increase in the permitted ambient temperature above 40 °C is possible by using suitable insulation materials. This should be discussed with the manufacturer, however.

The permitted temperature of the conveyed medium for the standard range is from -30 °C to +80 °C.

The fitting of a temperature barrier to the standard units between blower and motor allow for conveyed medium temperatures of up to 80 °C.

Sealing

Higher enclosure to IP 55 and IP 65 as well as tropical and moisture-proof insulation are possible for all motors.

If the blowers have to be gas- and air-tight to a certain extent, a rotary PTFE shaft seal can be fitted into the shaft bore. Further sealing options of the blower parts are flat gaskets or elastic sealants.

Corrosion protection

By choice of material (cast and sheet aluminium) the standard blowers are already nearly corrosion-resistant.

For special applications, the blowers may be painted or coated with plastic resin. the impellers can be manufactured from alloy 1.4301.

Blower speeds

The standard blowers are equipped with two-pole motors. Change-pole motors 4/2 or 4-pole motors, can be supplied on demand.

An alteration of the number of revolutions of the blower will change the total pressure rise, the flow volume and the power consumption as follows:

$$\begin{aligned} \dot{V}_2 &= \dot{V}_1 \frac{n_2}{n_1} & \dot{V} &= \text{flow volume} \\ \Delta p_{t2} &= \Delta p_{t1} \left(\frac{n_2}{n_1} \right)^2 & \Delta p_t &= \text{total pressure rise} \\ n_2 &= n_1 \frac{\dot{V}_2}{\dot{V}_1} & n &= \text{number of revolutions} \\ P_2 &= P_1 \left(\frac{n_2}{n_1} \right)^3 & P &= \text{power consumption} \\ & & f &= \text{frequency} \end{aligned}$$

Voltage and frequency

The motors of the standard version are made for a voltage of 230/400 V (Δ / Υ) or 400 V (Δ) three phase a.c. at 50 Hz mains frequency and for 230 V single phase a.c. in accordance with IEC 38. On demand the motors for 60 Hz mains frequency can also be supplied to IEC 38.

Special voltage and special frequency as well as motors for voltage change-over or multi-range voltage can be supplied on demand.

Permitted maximum voltage for three phase a.c. is 690 V and 277 V for single phase a.c.

An alteration of the mains frequency leads to a change of the motor speed (r.p.m.) and of the impeller whereby the total pressure rise, the flow volume and the power consumption change as follows:

$$\begin{aligned} n_2 &= n_1 \frac{f_2}{f_1} \\ \Delta p_{t2} &= \Delta p_{t1} \left(\frac{f_2}{f_1} \right)^2 \\ \dot{V}_2 &= \dot{V}_1 \frac{f_2}{f_1} \\ P_2 &= P_1 \left(\frac{f_2}{f_1} \right)^3 \end{aligned}$$

The characteristic curves and the power consumption of blowers with 60 Hz drive change as indicated in the technical data for each model.

1.7 Directions for operation and maintenance

Elektror low pressure blowers are equipped with sealed grooved ball bearings which do not need relubrication. The grease filling is sufficient for their operational life.

Inspection and eventual cleaning should be carried out at regular intervals with special attention to the safety instructions. Soiled and worn impellers cause an unbalance which may result in bearing failure.

Safety of operation as well as the indicated performance data are no longer guaranteed.

Conveying of solids is not permitted.

If the conveyed medium contains solid particles or other pollutants, they have to be removed before entering the blower by a filter on the intake side. Permeability of the filter must be ensured.

Conveying of explosive mixtures is not permitted.

Blower with open discharge or intake ports have to be equipped with a contact safety device in accordance with DIN EN 294 as far as such a device has not already been fitted in the factory.

The units have to be installed in weather-protected places and must not be exposed to strain by vibrations, shocks and percussions.

Units above 3 kW must be started in (Δ / Υ) configuration.

The instructions for installation and operation supplied with the blower unit have strictly to be adhered to.

1.8 Details for ordering

Blower type

Volumetric flow rate

Required total pressure or static pressure difference

Voltage, frequency, current (3- or 1-phase a. c.)

Ambient and conveyed medium temperature

Density of conveyed medium

Housing position

Accessories/special requirements

1.9 Remarks

Dimensions, technical data and descriptions are approximate only. Subject to modifications and error.

Low Pressure Blowers

3. Low Pressure Blowers

Standard blowers

page 11 to 15

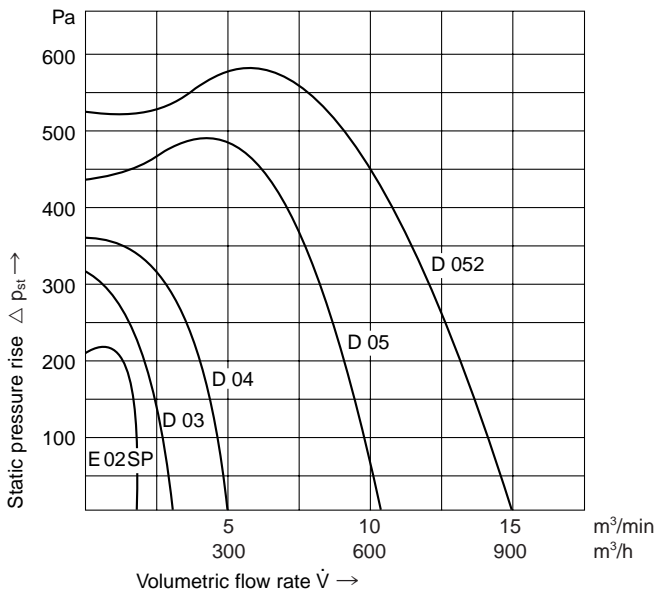

Standard blowers

page 16 to 21

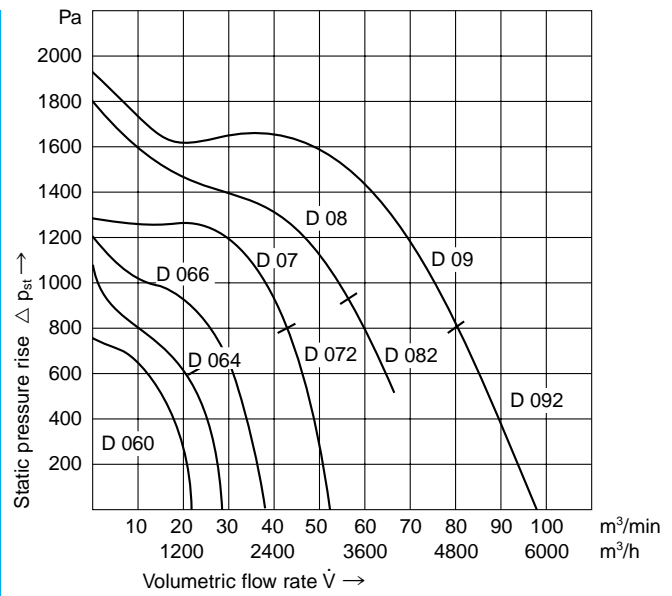

Twin blowers

page 22 to 28

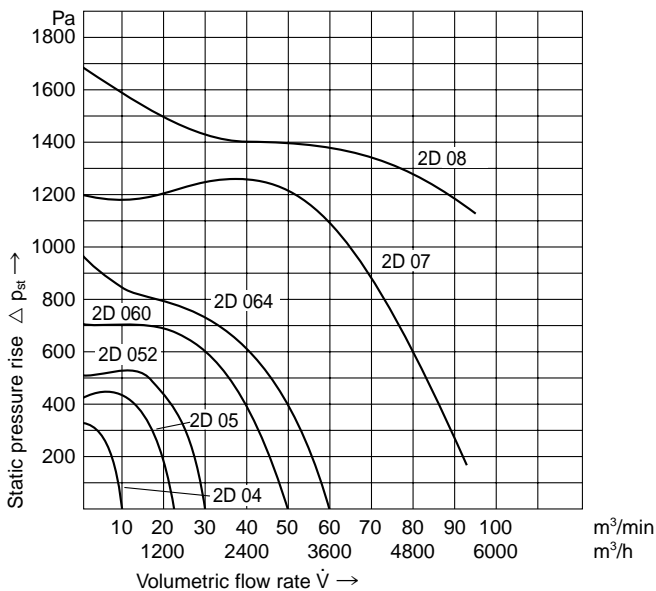

Compact blowers

page 34 to 36

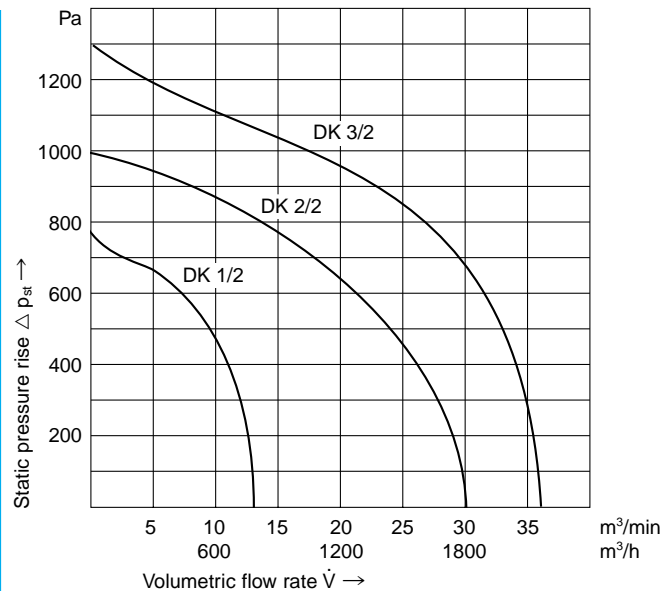

E02 SP

Standard blowers

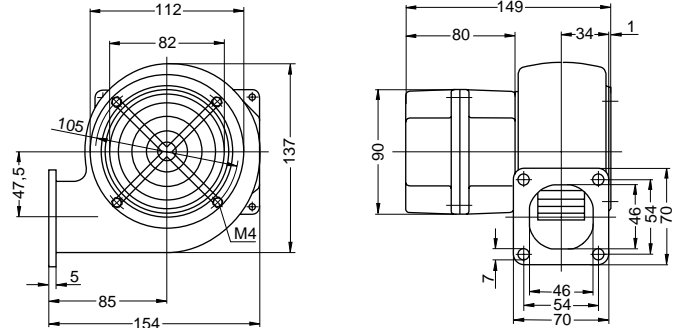

Dimensions in mm – subject to modifications

Type	Volumetric flow rate	Total pressure difference	Voltage	Frequency	Current consumption	Number of revolutions	Motor rating	Capacitor	Weight
	m ³ /min	Pa	V	Hz	A	min ⁻¹	kW	μF/V	kg
E02 SP	1,75	210	230	50	0,51	2630	0,05	–	2,3
E02 SP	1,9	310	230	60	0,38	2840	0,05	–	2,3

50 Hz

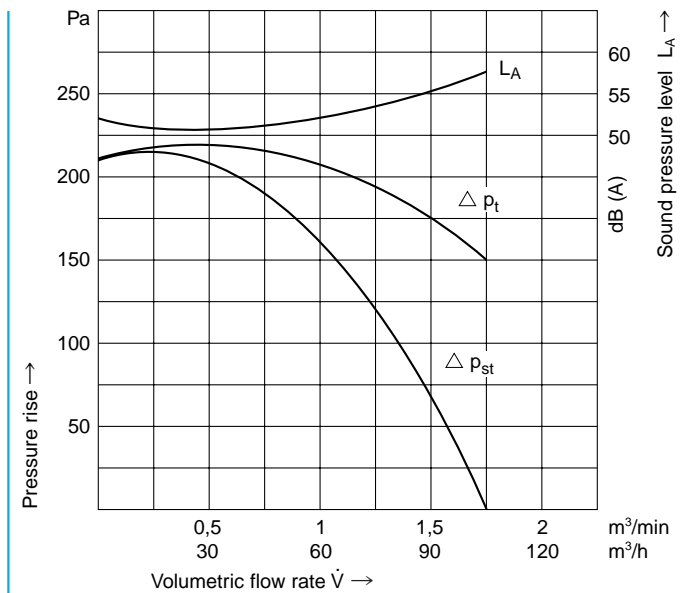

60 Hz

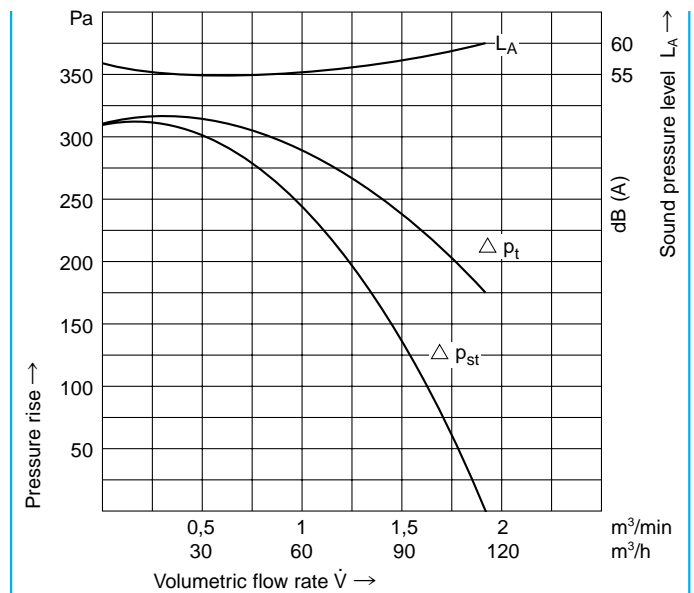

D 03, E 03

Standard blowers

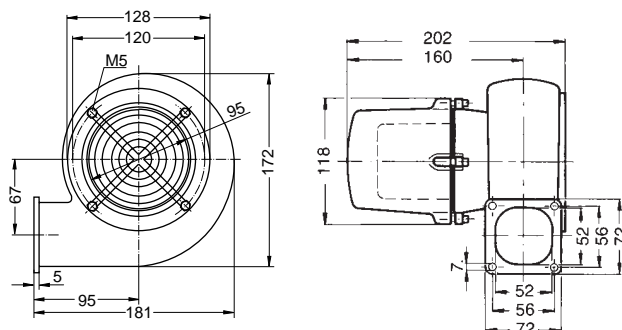

Dimensions in mm – subject to modifications

Type	Volumetric-flow rate	Total pressure difference	Voltage	Frequency	Current consumption	Number of revolutions	Motor rating	Capacitor	Weight
	m ³ /min	Pa	V	Hz	A	min ⁻¹	kW	μF/V	kg
D 03	3,2	330	230/400	50	0,23/0,13	2820	0,03	–	3,7
D 03	3,8	480	277/480	60	0,28/0,16	3400	0,05	–	3,7
E 03	3,2	330	230	50	0,40	2880	0,03	3/450	3,9
E 03	3,8	480	230	60	0,50	3350	0,05	3/450	3,9

50 Hz

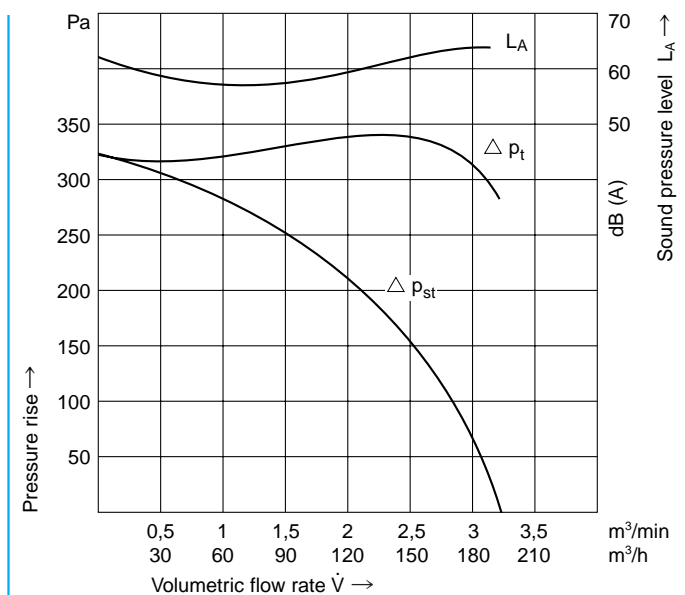

60 Hz

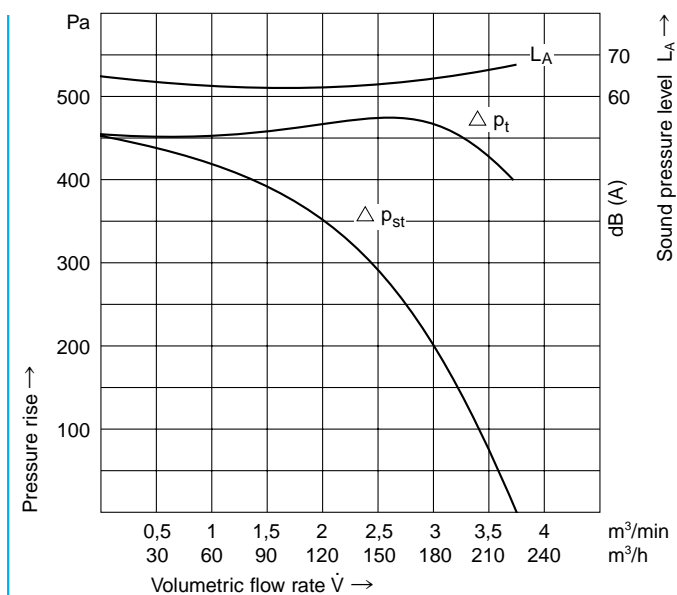

D 04, E 04

Standard blowers

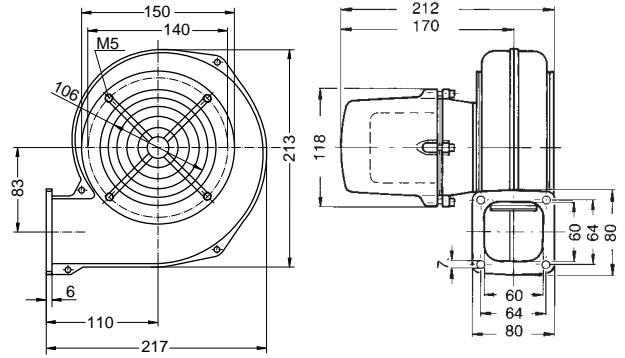

Dimensions in mm – subject to modifications

Type	Volumetric flow rate	Total pressure difference	Voltage	Frequency	Current consumption	Number of revolutions	Motor rating	Capacitor	Weight
	m ³ /min	Pa	V	Hz	A	min ⁻¹	kW	μF/V	kg
D 04	5,0	350	230/400	50	0,43/0,25	2850	0,07	–	4,5
D 04	6,0	500	277/480	60	0,48/0,28	3400	0,12	–	4,5
E 04	5,0	350	230	50	0,8	2850	0,07	3/450	4,7
E 04	6,0	500	230	60	0,75	3400	0,12	3/450	4,7

50 Hz

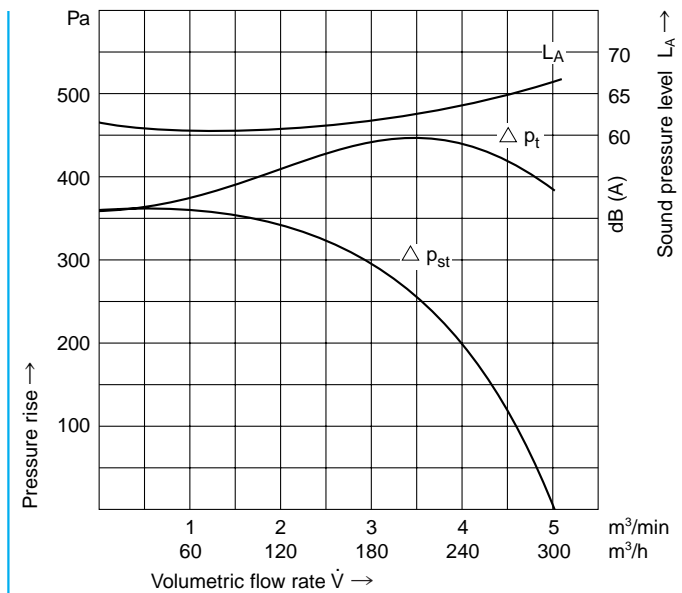

60 Hz

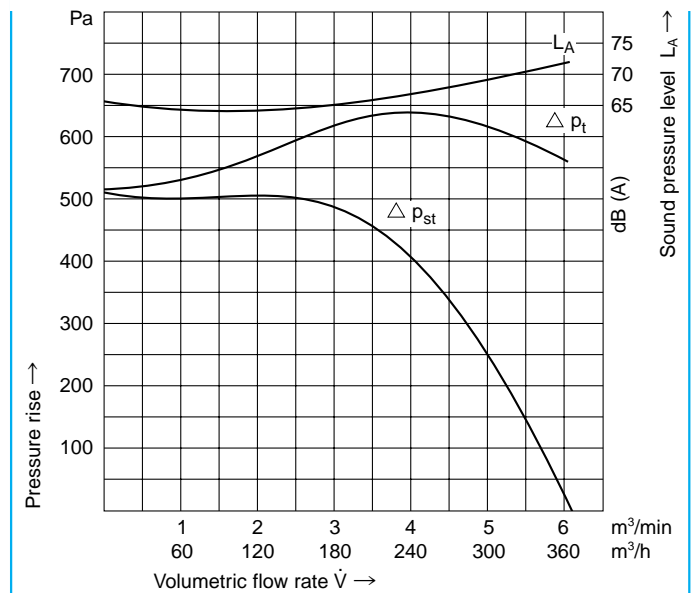

D 05, E 05

Standard blowers

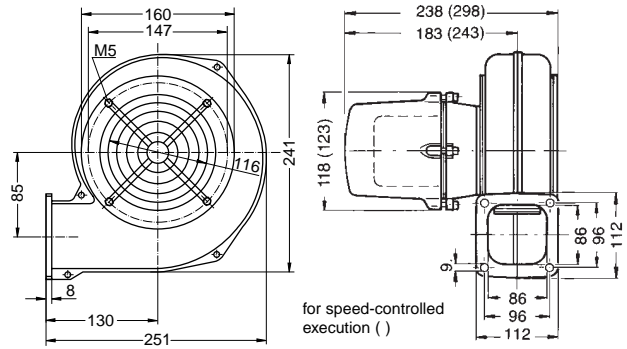

Design with foot base on demand

Dimensions in mm – subject to modifications

Type	Volumetric-flow rate	Total pressure difference	Voltage	Frequency	Current consumption	Number of revolutions	Motor rating	Capacitor	Weight
	m ³ /min	Pa	V	Hz	A	min ⁻¹	kW	μF/V	kg
D 05	10,0	430	230/400	50	0,57/0,33	2550	0,13	–	5,0
D 05	11,0	620	277/480	60	0,78/0,45	3000	0,22	–	5,0
E 05	10,0	430	230	50	1,1	2550	0,14	3/450	5,2
E 05	9,5	620	230	60	0,9	3300	0,14	3/450	5,2

50 Hz

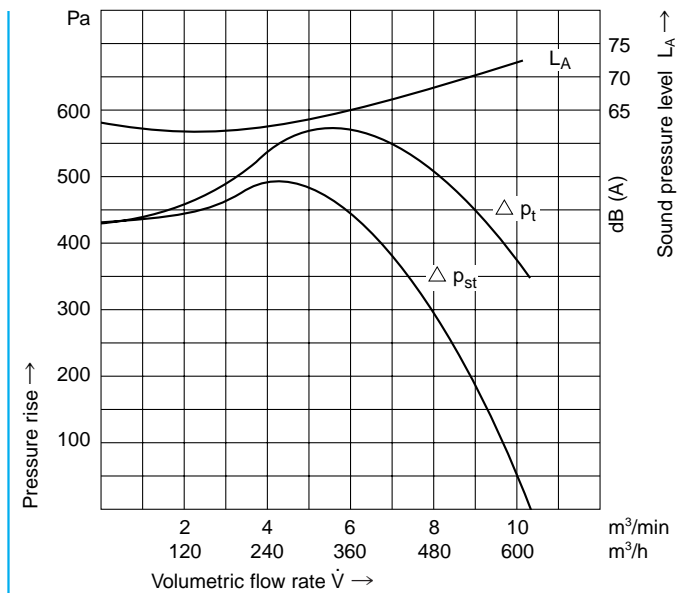

60 Hz

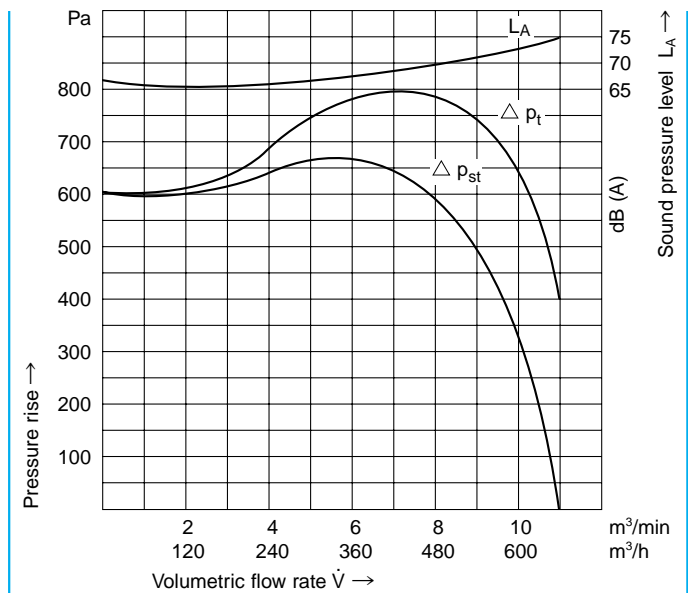

D 052, E 052

Standard blowers

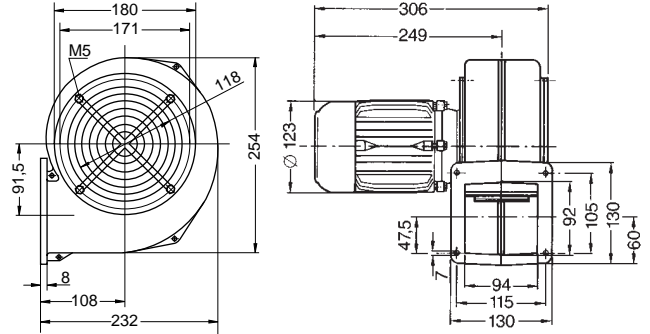

Dimensions in mm – subject to modifications

Type	Volumetric flow rate	Total pressure difference	Voltage	Frequency	Current consumption	Number of revolutions	Motor rating	Capacitor	Weight
	m ³ /min	Pa	V	Hz	A	min ⁻¹	kW	μF/V	kg
D 052	15	530	230/400	50	1,7/0,95	2710	0,28	–	6,4
D 052	17,5	760	277/480	60	1,56/0,9	3180	0,45	–	6,4
E 052	14	530	230	50	1,9	2560	0,24	10/450	6,4
E 052	17,5	760	230	60	2,7	3100	0,43	8/450	6,4

50 Hz

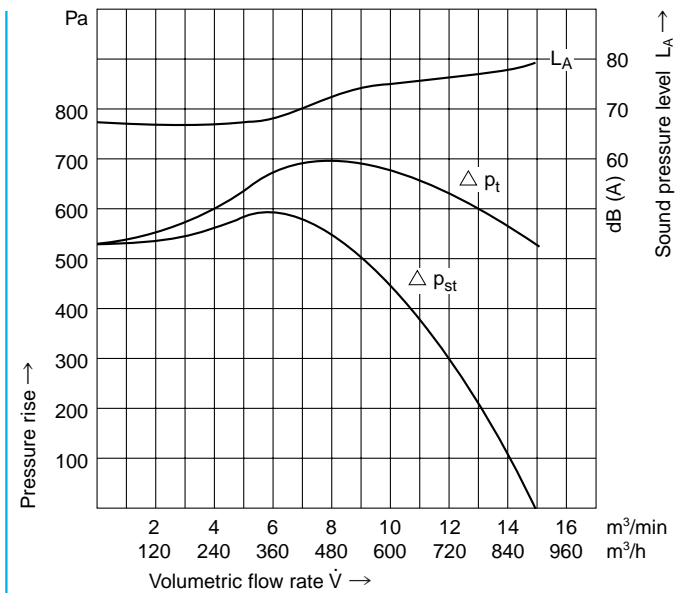

60 Hz

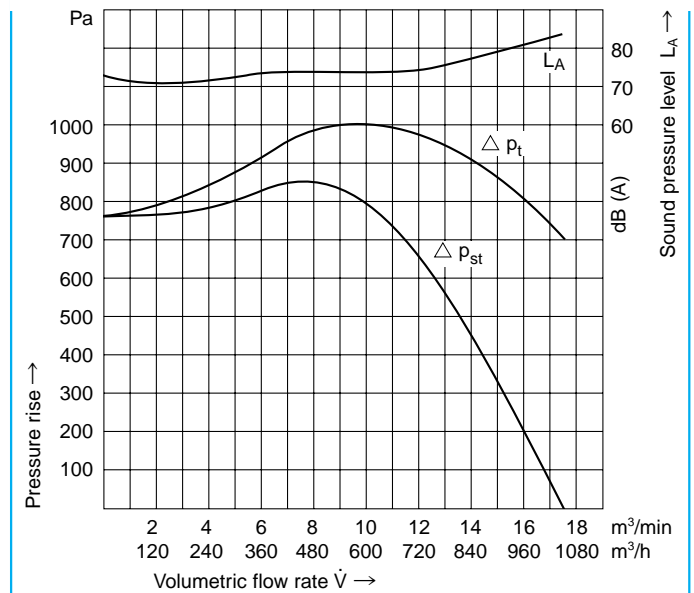

D 060, E 060

Standard blowers

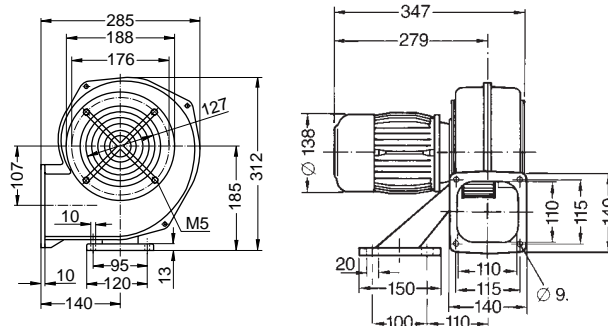

Dimensions in mm – subject to modifications

Type	Volumetric-flow rate	Total pressure difference	Voltage	Frequency	Current consumption	Number of revolutions	Motor rating	Capacitor	Weight
	m ³ /min	Pa	V	Hz	A	min ⁻¹	kW	μF/V	kg
D 060	22	730	230/400	50	2,4/1,4	2780	0,53	–	9,6
D 060	27	1040	277/480	60	3,45/2,0	3350	0,98	–	10,6
E 060	22	730	230	50	3,8	2790	0,53	16/450	11,1
E 060	26	1040	230	60	6,0	3250	0,88	20/450	11,1

50 Hz

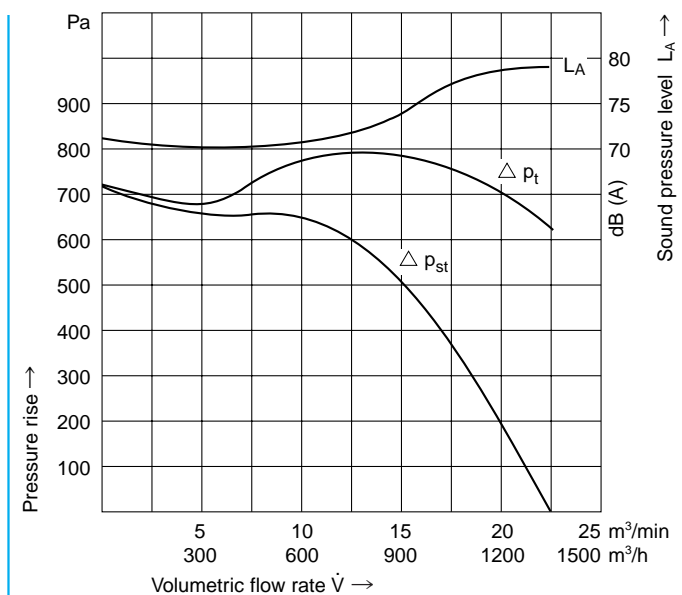

60 Hz

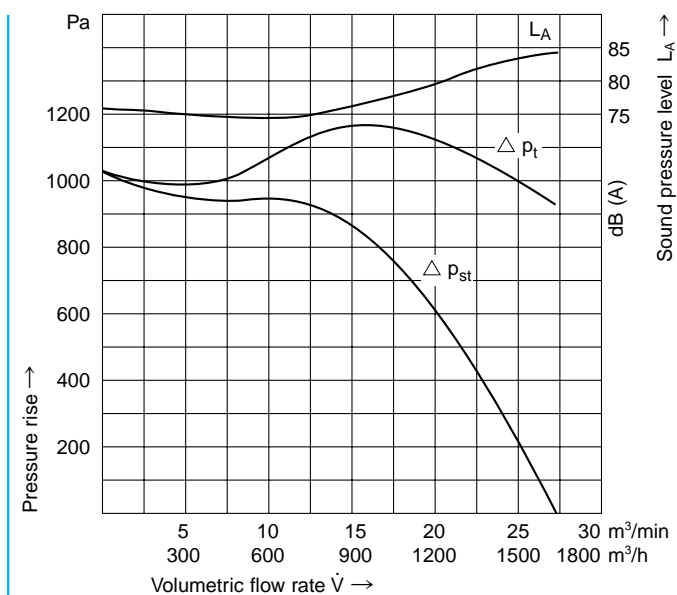

D 064, E 064

Standard blowers

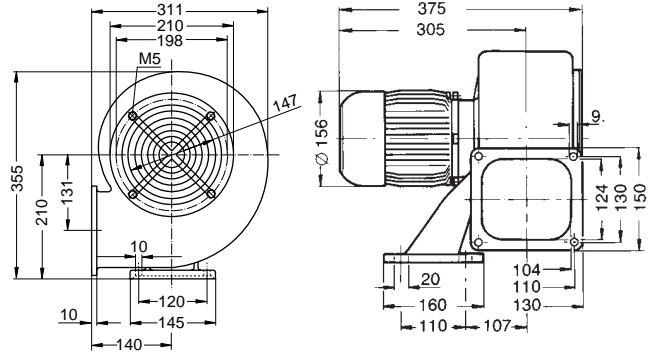

Dimensions in mm – subject to modifications

Type	Volumetric flow rate	Total pressure difference	Voltage	Frequency	Current consumption	Number of revolutions	Motor rating	Capacitor	Weight
	m ³ /min	Pa	V	Hz	A	min ⁻¹	kW	μF/V	kg
D 064	27	1050	230/400	50	3,8/2,2	2830	0,90	–	14,9
D 064	32	1550	277/480	60	4,7/2,7	3310	1,35	–	14,9
E 064	28	1000	230	50	6,0	2840	0,90	30/450	16,9
E 064	33	1500	230	60	9,0	3350	1,4	30/450	16,9

50 Hz

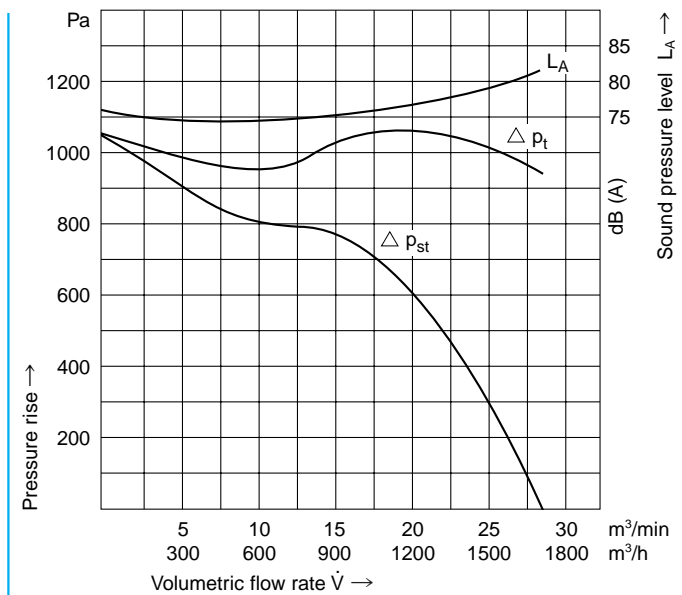

60 Hz

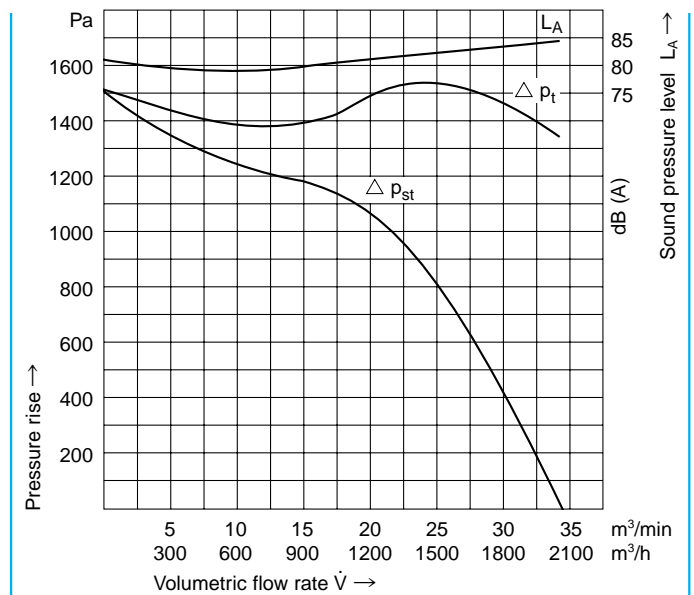

D 066, E 066

Standard blowers

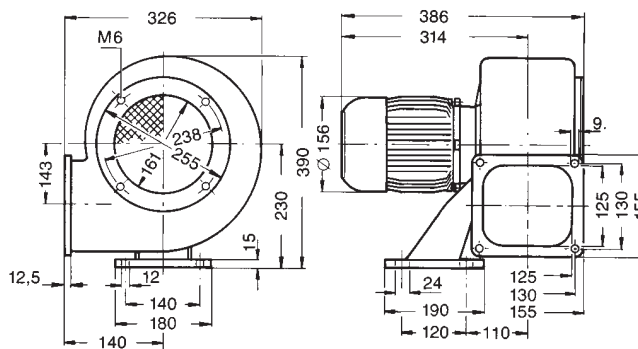

Dimensions in mm – subject to modifications

Type	Volumetric-flow rate	Total pressure difference	Voltage	Frequency	Current consumption	Number of revolutions	Motor rating	Capacitor	Weight
	m ³ /min	Pa	V	Hz	A	min ⁻¹	kW	μF/V	kg
D 066	38	1200	230/400	50	5,9/3,4	2820	1,4	–	18,1
D 066	38	1300	277/480	60	6,1/3,5	3420	1,6	–	18,1
E 066	36	1200	230	50	8,0	2740	1,3	30/450	18,1
E 066	37	1380	230	60	9,5	3350	1,5	30/450	18,1

50 Hz

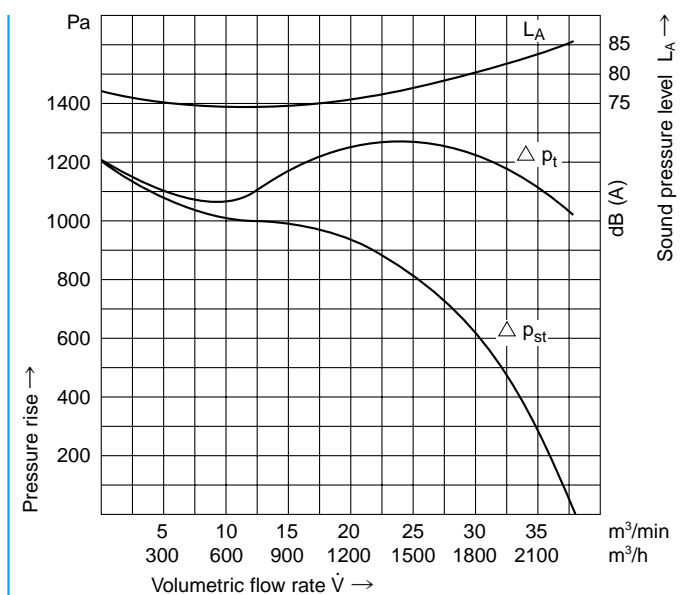

60 Hz

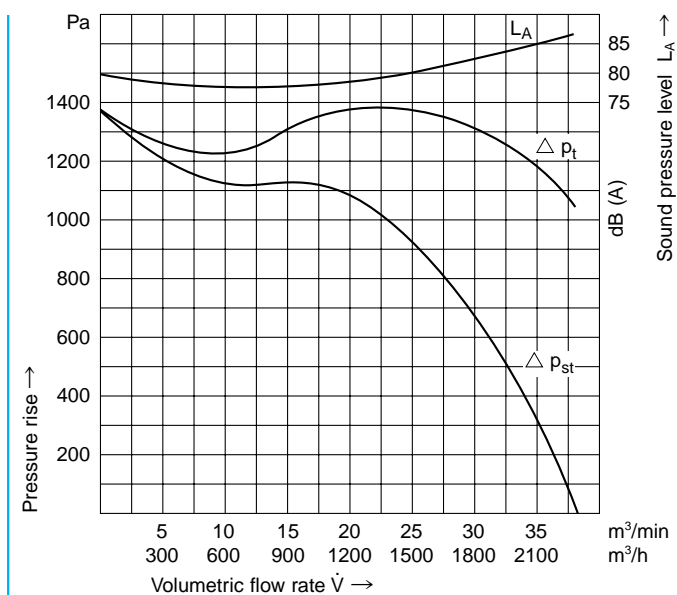

D 07, D 072

Standard blowers

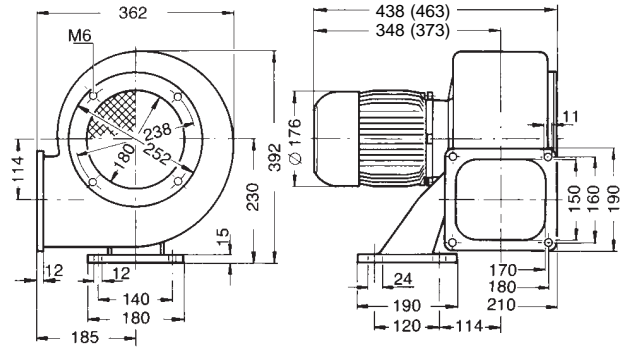

D 072 ()

Dimensions in mm – subject to modifications

Type	Volumetric flow rate	Total pressure difference	Voltage	Frequency	Current consumption	Number of revolutions	Motor rating	Capacitor	Weight
	m ³ /min	Pa	V	Hz	A	min ⁻¹	kW	μF/V	kg
D 07	41	1200	230/400	50	7,5/4,3	2830	1,8	–	22
D 07	41	1600	277/480	60	7,6/4,4	3440	2,4	–	22
D 072	52	1200	230/400	50	10,0/5,8	2860	2,6	–	24
D 072	52	1600	277/480	60	10,2/5,9	3430	3,4	–	24

50 Hz

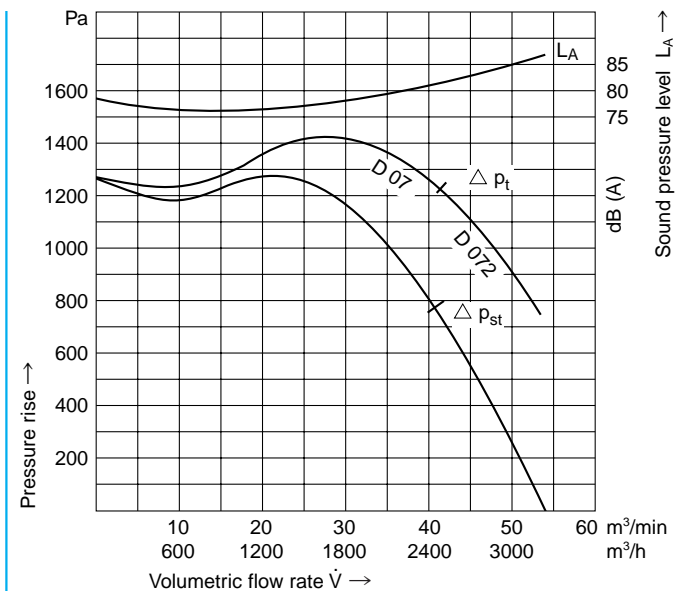

D 07 not to be operated with free discharge.

60 Hz

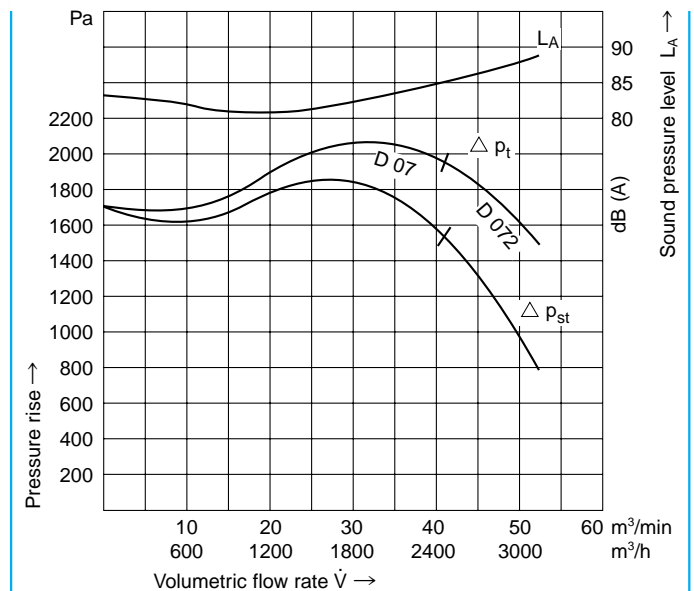

Blower not to be operated with free discharge.

D 08, D 082

Standard blowers

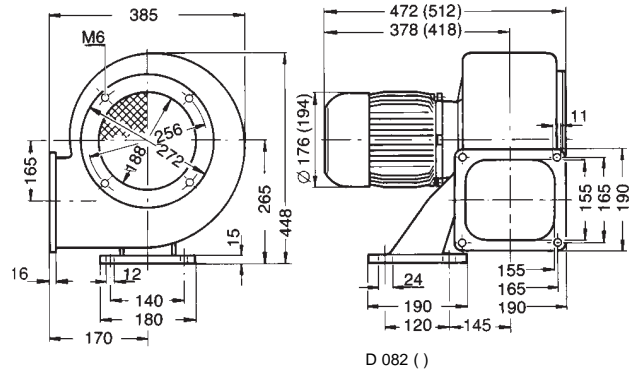

Dimensions in mm – subject to modifications

Type	Volumetric-flow rate	Total pressure difference	Voltage	Frequency	Current consumption	Number of revolutions	Motor rating	Capacitor	Weight
	m ³ /min	Pa	V	Hz	A	min ⁻¹	kW	μF/V	kg
D 08	50	1700	230/400	50	10,0/5,8	2860	2,6	–	29
D 08	50	2300	277/480	60	9,7/5,6	3450	3,2	–	29
D 082	62	1700	230/400	50	11,8/6,8	2830	3,1	–	31
D 082	58	2300	277/480	60	11,8/6,8	3450	3,8	–	31

50 Hz

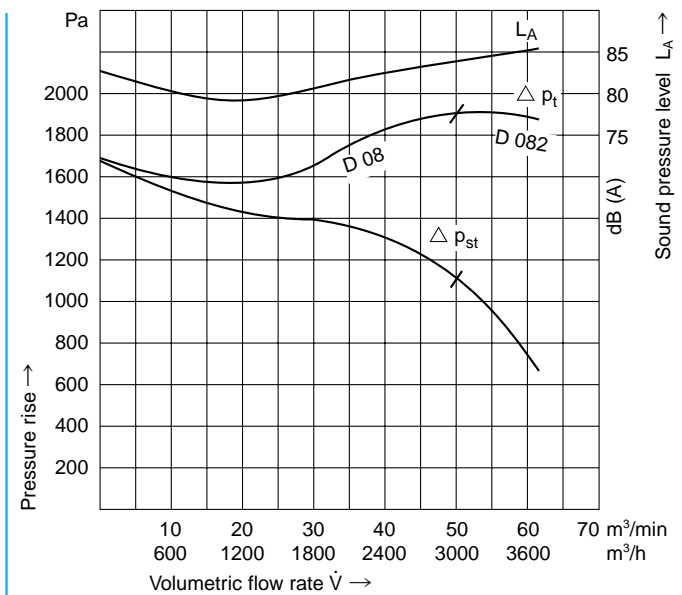

Blower not to be operated with free discharge.

60 Hz

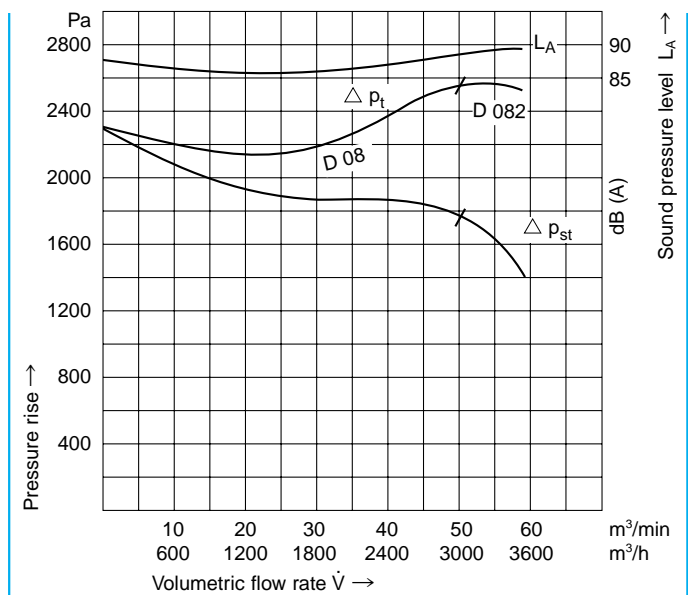

Blower not to be operated with free discharge.

D 09, D 092

Standard blowers

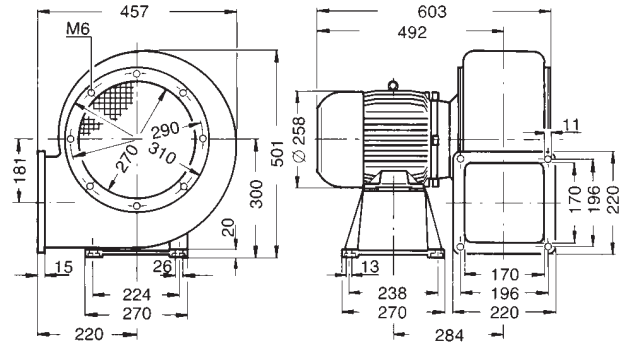

Dimensions in mm – subject to modifications

Type	Volumetric flow rate	Total pressure difference	Voltage	Frequency	Current consumption	Number of revolutions	Motor rating	Capacitor	Weight
	m ³ /min	Pa	V	Hz	A	min ⁻¹	kW	μF/V	kg
D 09	80	1900	400 Δ	50	11,8	2880	5,5	–	66
D 09	80	2700	480 Δ	60	10,5	3500	6,0	–	66
D 092	95	1900	400 Δ	50	15,0	2900	7,0	–	71
D 092	91	2700	480 Δ	60	12,0	3530	7,0	–	71

50 Hz

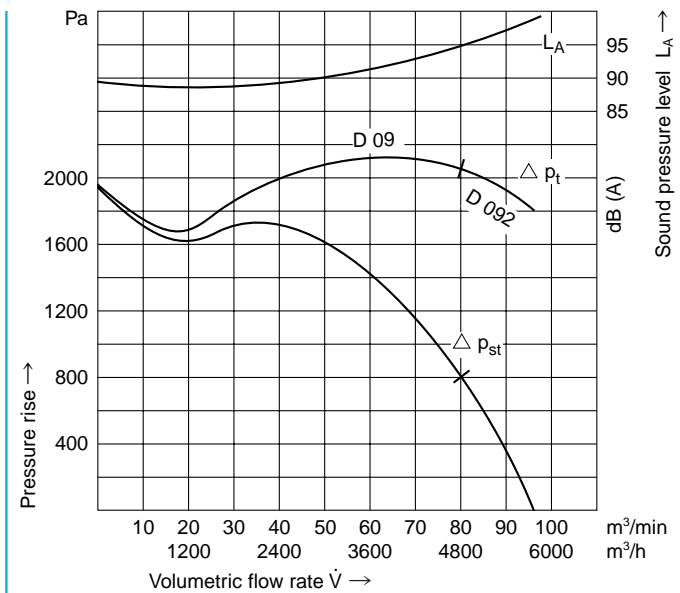

D 09 not to be operated with free discharge.

60 Hz

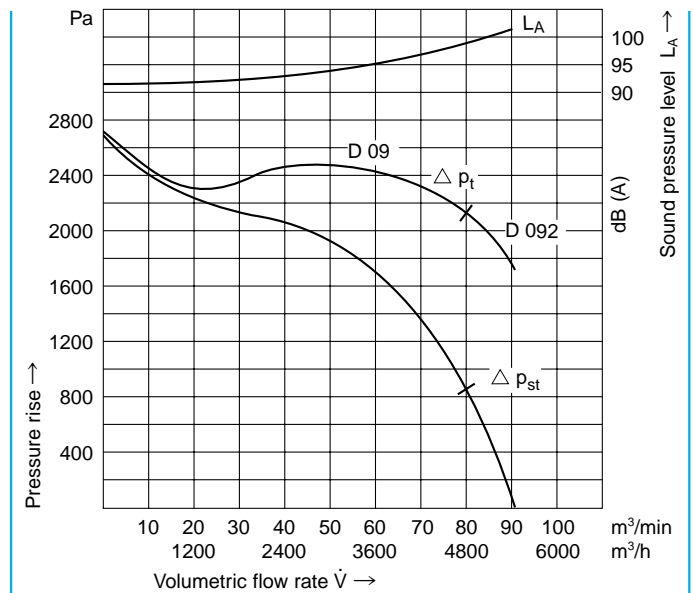

D 09 not to be operated with free discharge.

2D 04

Twin blowers

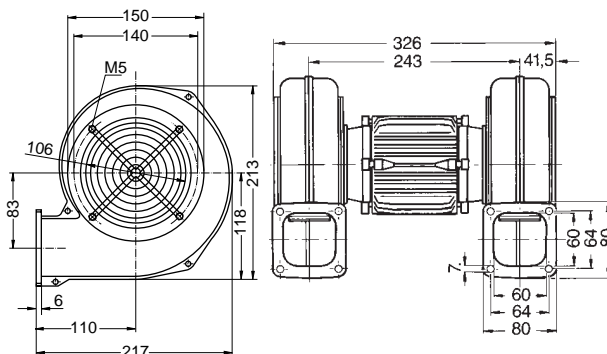

Dimensions in mm – subject to modifications

Type	Volumetric-flow rate	Total pressure difference	Voltage	Frequency	Current consumption	Number of revolutions	Motor rating	Capacitor	Weight
	m ³ /min	Pa	V	Hz	A	min ⁻¹	kW	μF/V	kg
2D 04	10	350	230/400	50	0,61/0,35	2830	0,14	–	6,7
2D 04	12	500	277/480	60	0,87/0,5	3320	0,24	–	6,7

50 Hz

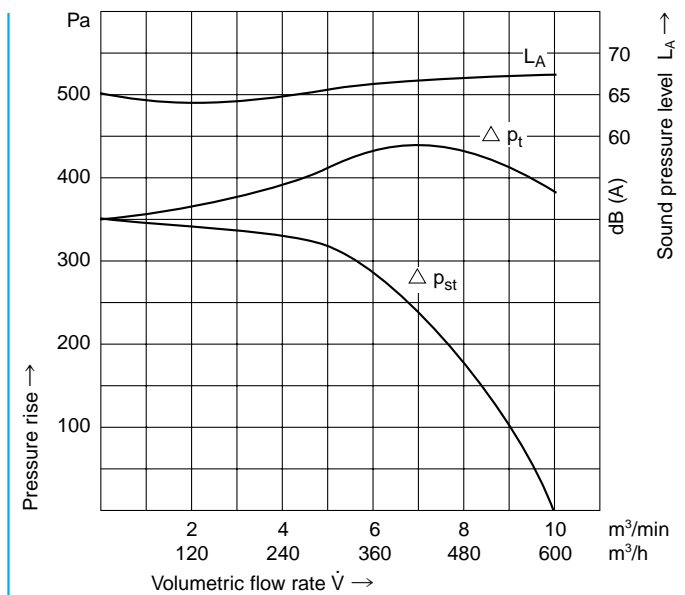

60 Hz

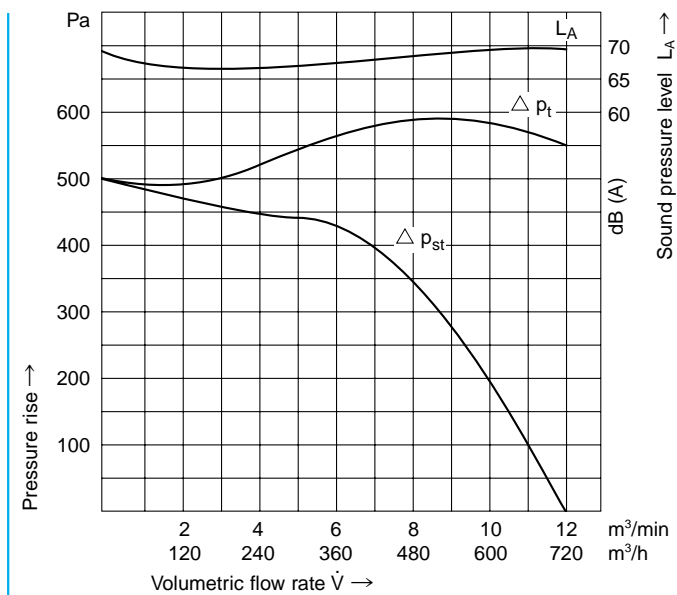

2D 05

Twin blowers

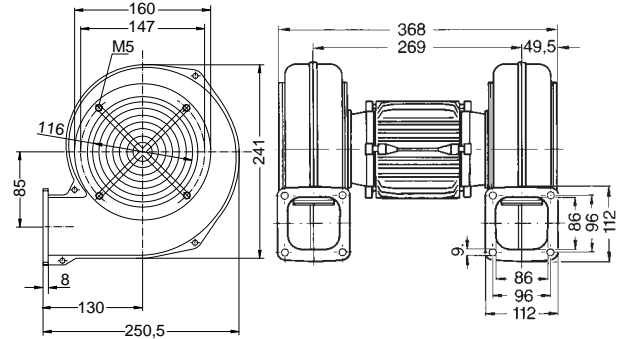

Dimensions in mm – subject to modifications

Type	Volumetric flow rate	Total pressure difference	Voltage	Frequency	Current consumption	Number of revolutions	Motor rating	Capacitor	Weight
	m ³ /min	Pa	V	Hz	A	min ⁻¹	kW	μF/V	kg
2D 05	21	430	230/400	50	1,91/1,1	2770	0,35	–	8,4
2D 05	24	620	277/480	60	2,15/1,25	3200	0,55	–	8,4

50 Hz

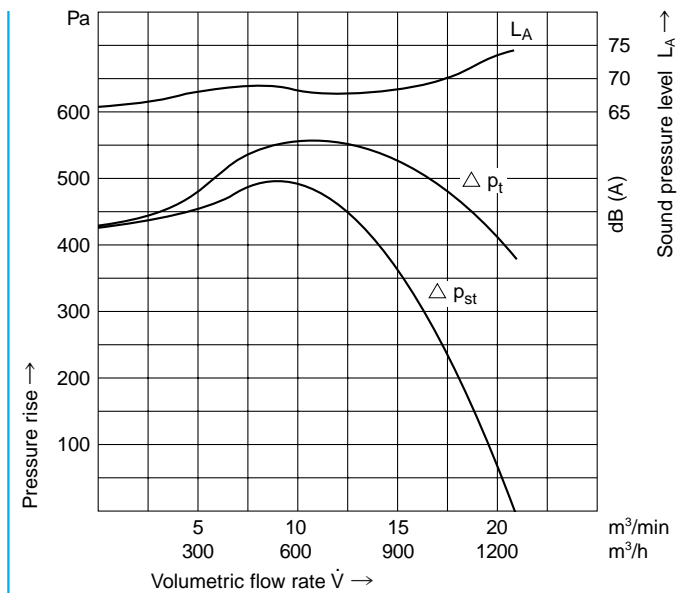

60 Hz

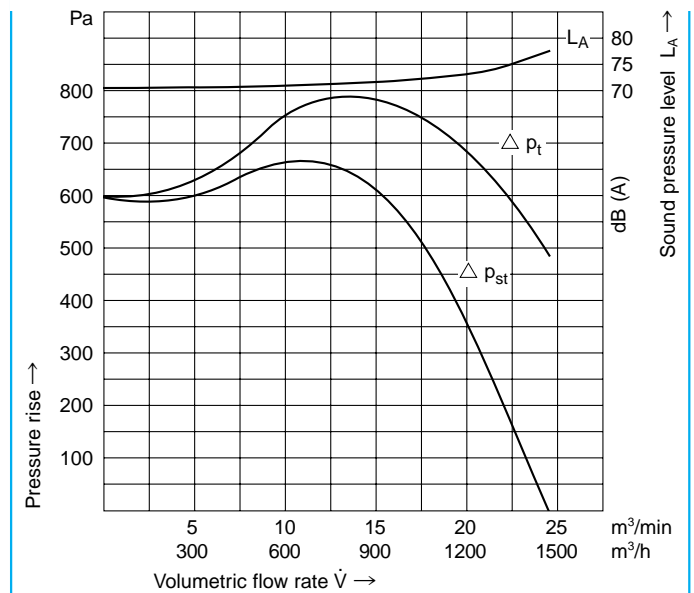

2D 052

Twin blowers

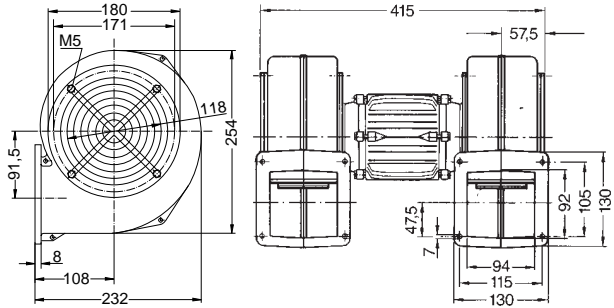
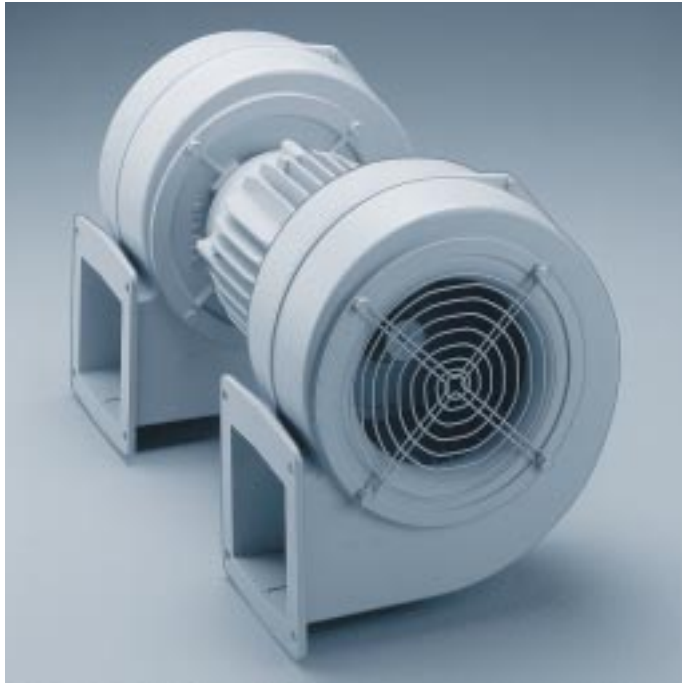

Dimensions in mm – subject to modifications

Type	Volumetric-flow rate	Total pressure difference	Voltage	Frequency	Current consumption	Number of revolutions	Motor rating	Capacitor	Weight
	m ³ /min	Pa	V	Hz	A	min ⁻¹	kW	μF/V	kg
2D 052	30	530	230/400	50	2,7/1,5	2850	0,56	–	11,0
2D 052	30	760	277/480	60	2,7/1,5	3420	0,80	–	11,0

50 Hz

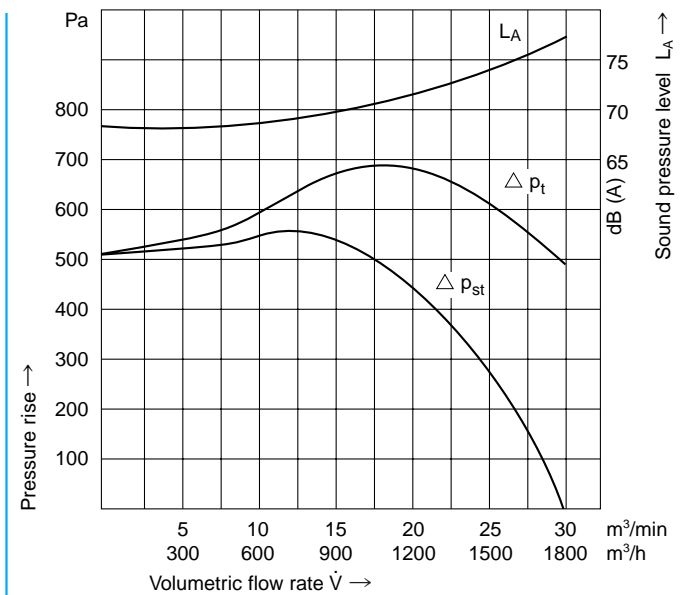

60 Hz

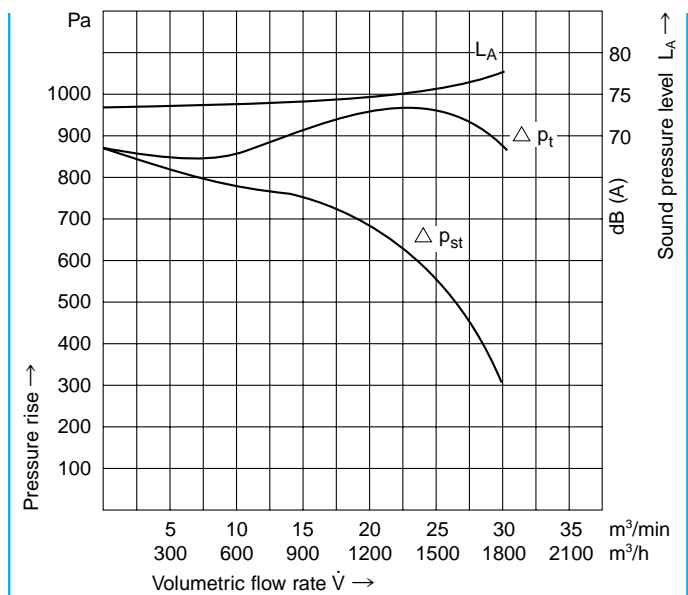

Blower not to be operated with free discharge.

2D 060

Twin blowers

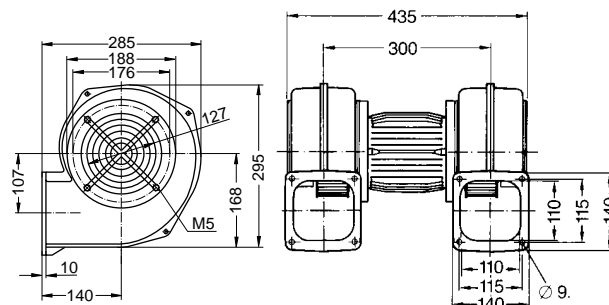

Dimensions in mm – subject to modifications

Type	Volumetric flow rate	Total pressure difference	Voltage	Frequency	Current consumption	Number of revolutions	Motor rating	Capacitor	Weight
	m ³ /min	Pa	V	Hz	A	min ⁻¹	kW	μF/V	kg
2D 060	50	730	230/400	50	6,4/3,7	2900	1,25	–	18,8
2D 060	54	1040	277/480	60	6,1/3,5	3470	1,75	–	18,8

50 Hz

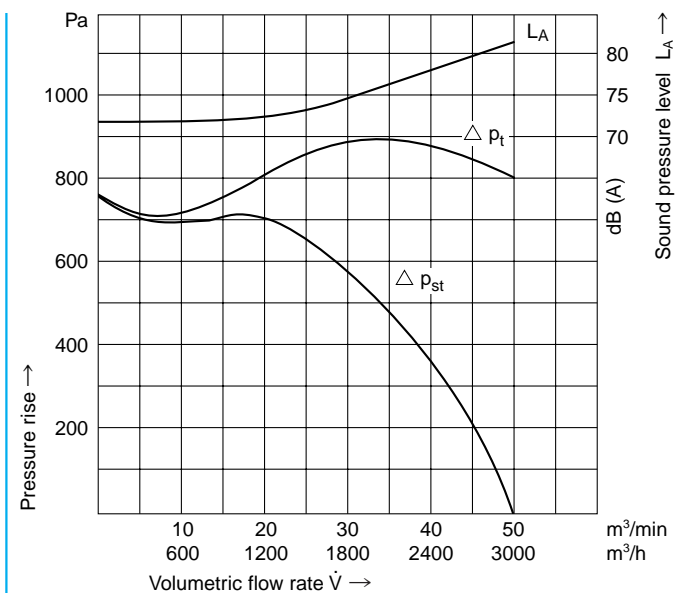

60 Hz

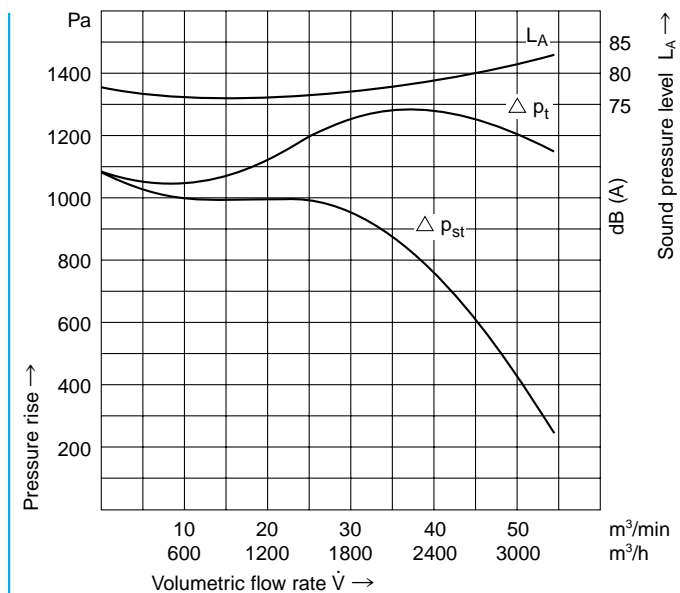

Blower not to be operated with free discharge.

2D 064

Twin blowers

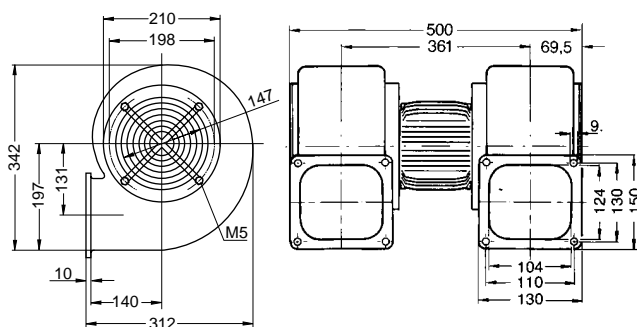

Dimensions in mm – subject to modifications

Type	Volumetric flow rate	Total pressure difference	Voltage	Frequency	Current consumption	Number of revolutions	Motor rating	Capacitor	Weight
	m ³ /min	Pa	V	Hz	A	min ⁻¹	kW	μF/V	kg
2D 064	60	1000	230/400	50	6,3/3,6	2870	1,8	–	25
2D 064	57	1440	277/480	60	6,4/3,7	3460	2,2	–	25

50 Hz

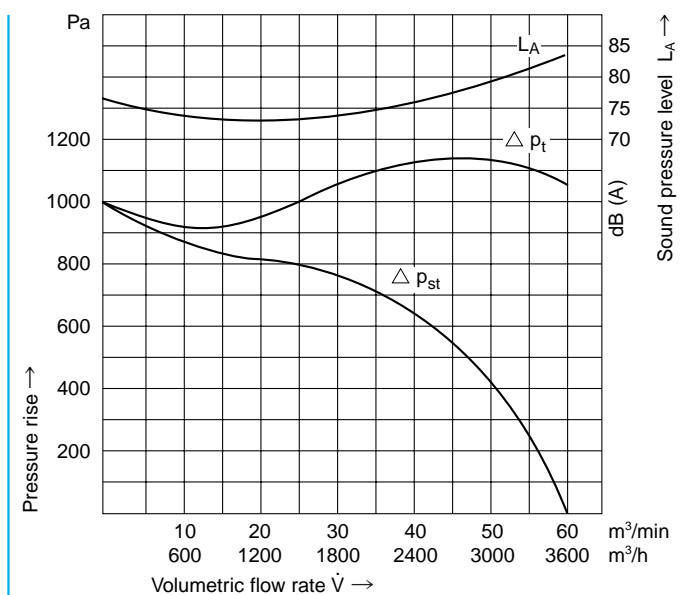

60 Hz

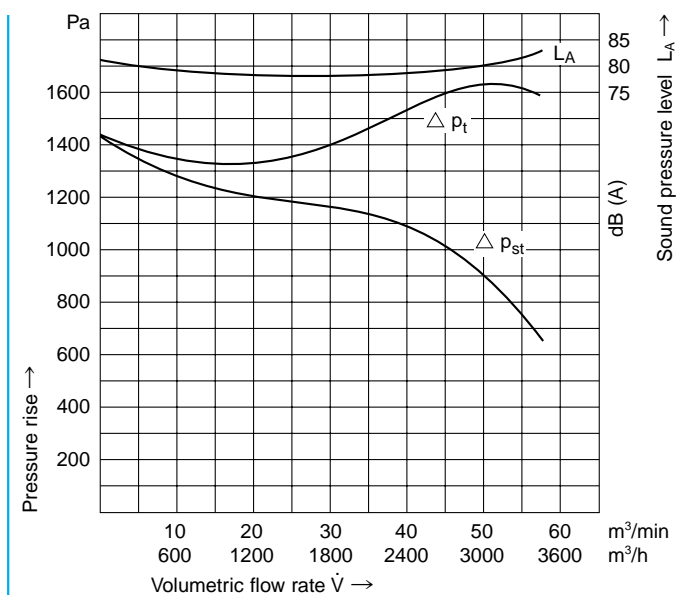

Blower not to be operated with free discharge.

2D 07

Twin blowers

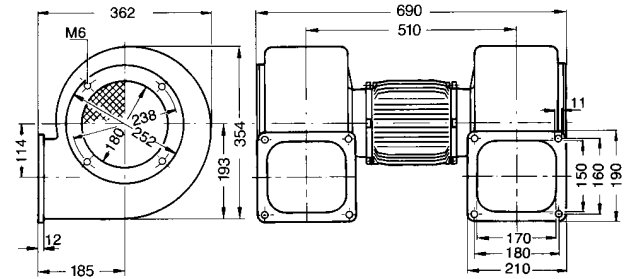

Dimensions in mm – subject to modifications

Type	Volumetric flow rate	Total pressure difference	Voltage	Frequency	Current consumption	Number of revolutions	Motor rating	Capacitor	Weight
	m ³ /min	Pa	V	Hz	A	min ⁻¹	kW	μF/V	kg
2D 07	94	1200	400 Δ	50	9,5	2930	4,5	–	50
2D 07	77	1600	480 Δ	60	8,7	3540	4,8	–	50

50 Hz

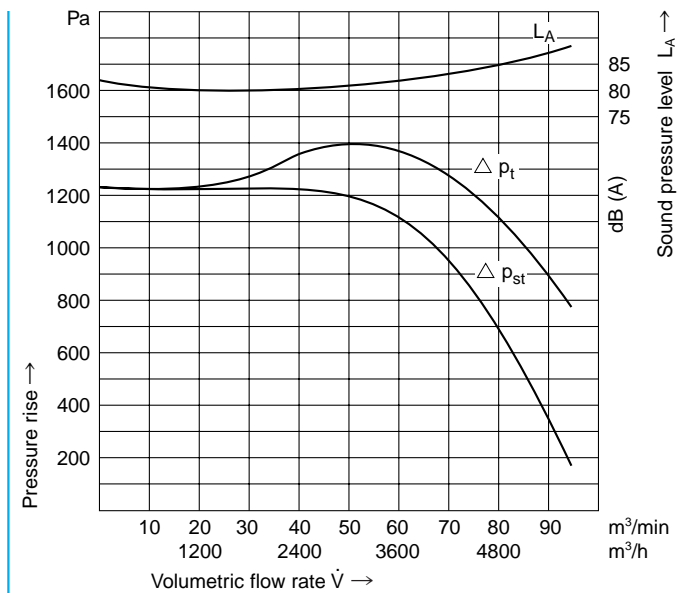

Blower not to be operated with free discharge.

60 Hz

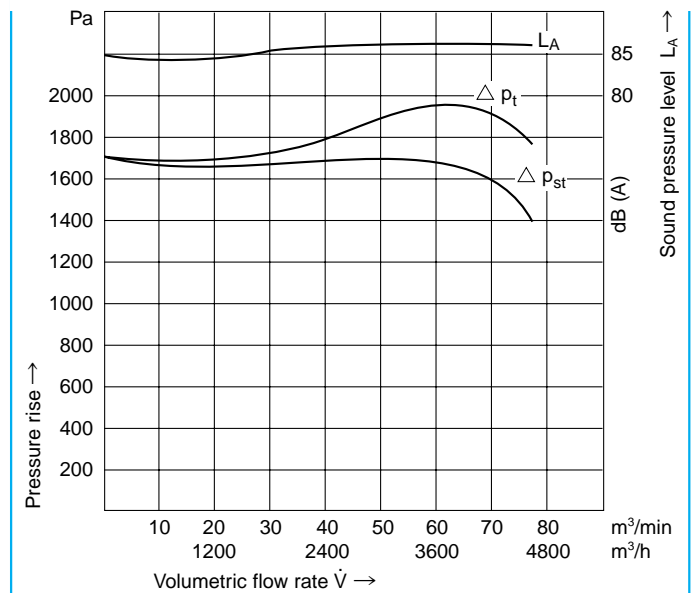

Blower not to be operated with free discharge.

2D 08

Twin blowers

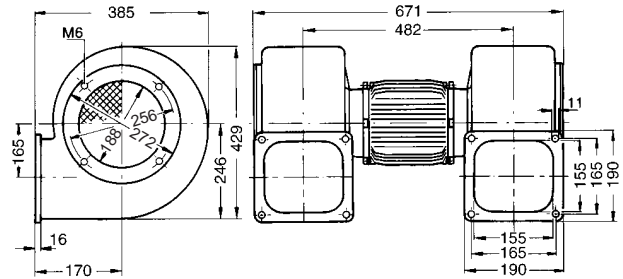

Dimensions in mm – subject to modifications

Type	Volumetric flow rate	Total pressure difference	Voltage	Frequency	Current consumption	Number of revolutions	Motor rating	Capacitor	Weight
	m ³ /min	Pa	V	Hz	A	min ⁻¹	kW	μF/V	kg
2D 08	95	1700	400 Δ	50	10,0	2910	5,0	–	52
2D 08	95	2300	480 Δ	60	10,0	3520	5,8	–	52

50 Hz

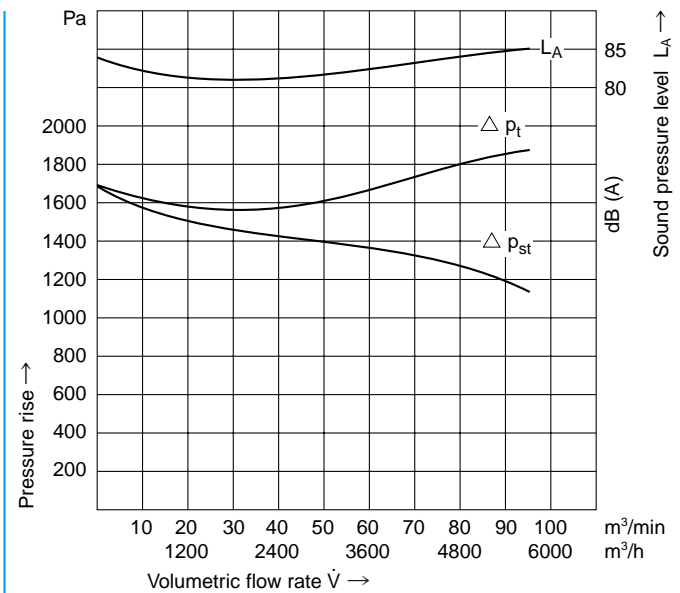

Blower not to be operated with free discharge.

60 Hz

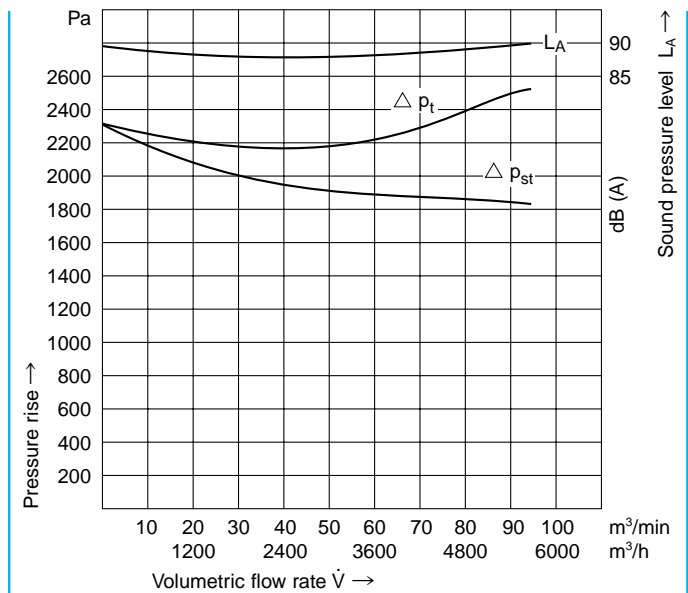

Blower not to be operated with free discharge.

DK 1/2, EK 1/2

Compact blowers

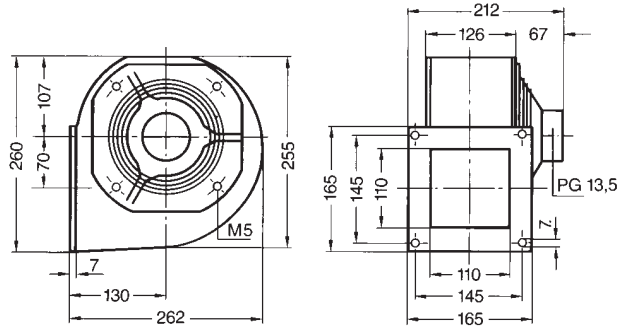

Dimensions in mm – subject to modifications

Type	Volumetric-flow rate	Total pressure difference	Voltage	Frequency	Current consumption	Number of revolutions	Motor rating	Capacitor	Weight
	m ³ /min	Pa	V	Hz	A	min ⁻¹	kW	μF/V	kg
DK 1/2	12,5	750	380–520 Y	50	0,6	1650	0,34	–	7,0
	11,5	1000		60					
EK 1/2	11	750	230	50	1,53	2100	0,35	5/450	7,0
EK 1/2	10	1000	220	60	2,1	2600	0,45	5/450	7,0

50 Hz

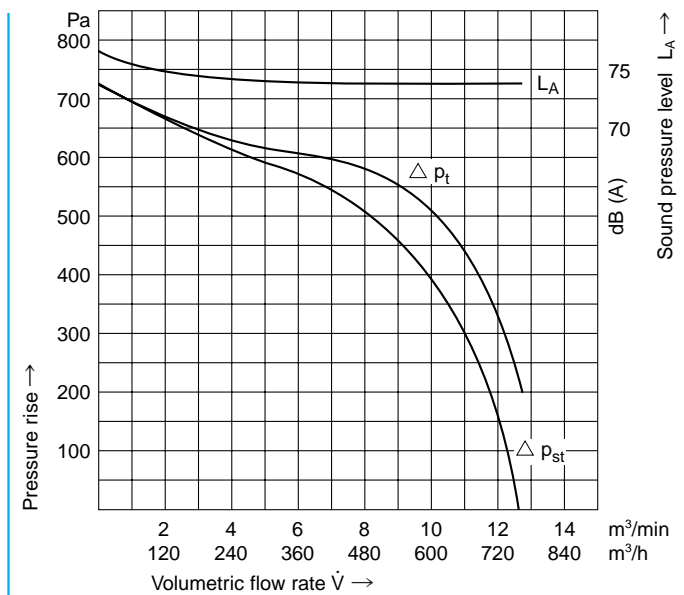

60 Hz

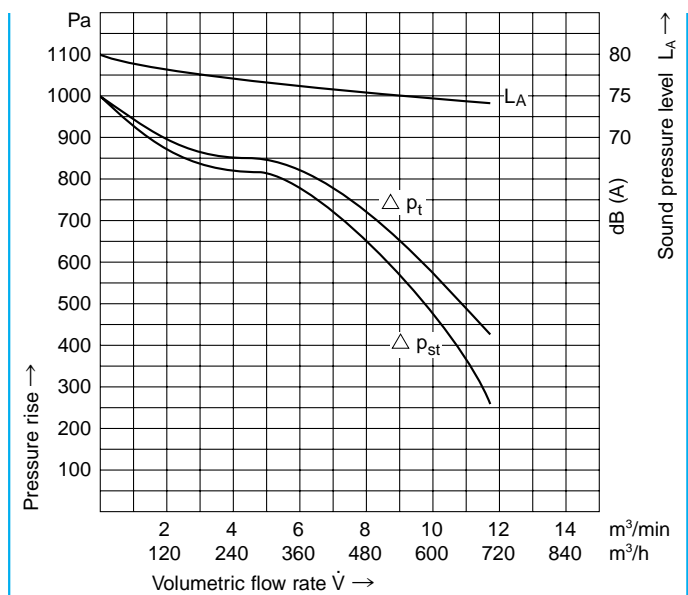

Blower not to be operated with free discharge.

DK 2/2

Compact blowers

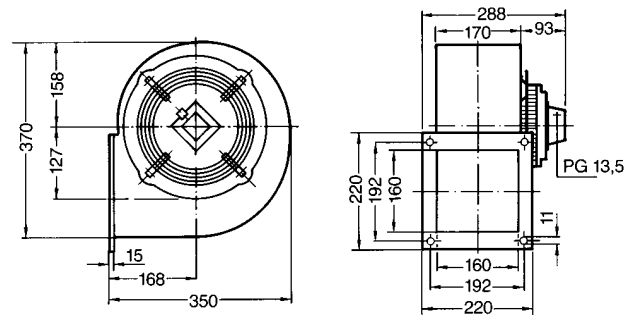

Dimensions in mm – subject to modifications

Type	Volumetric flow rate	Total pressure difference	Voltage	Frequency	Current consumption	Number of revolutions	Motor rating	Capacitor	Weight
	m ³ /min	Pa	V	Hz	A	min ⁻¹	kW	μF/V	kg
DK 2/2	30	1000	230/400	50	3,0/1,7	1740	0,5	–	16,0
DK 2/2	32	1400	277/480	60	3,7/2,1	2280	0,9	–	16,0

50 Hz

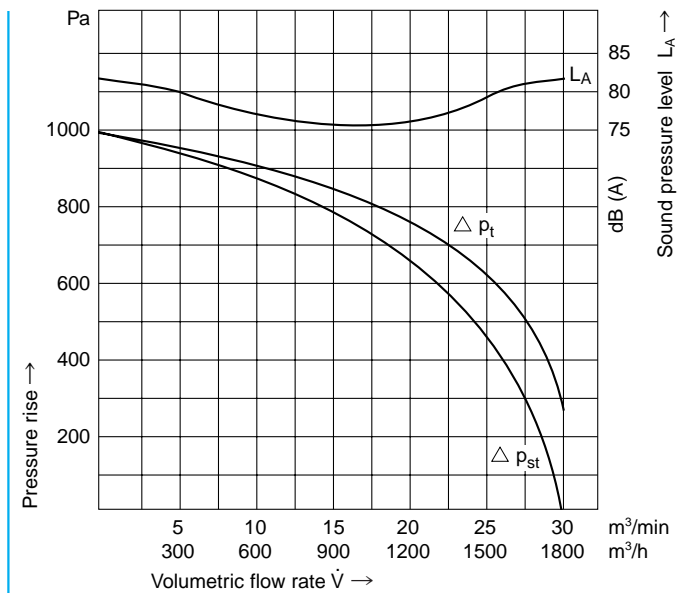

60 Hz

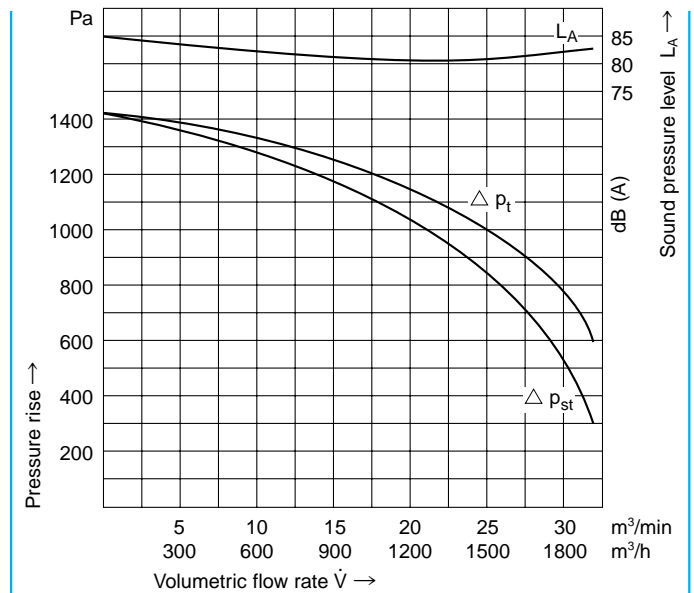

Blower not to be operated with free discharge.

DK 3/2

Compact blowers

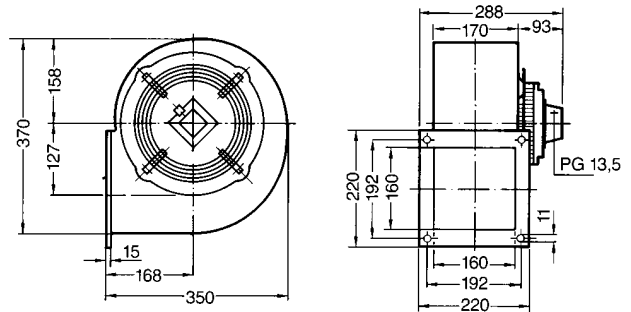

Dimensions in mm – subject to modifications

Type	Volumetric-flow rate	Total pressure difference	Voltage	Frequency	Current consumption	Number of revolutions	Motor rating	Capacitor	Weight
	m ³ /min	Pa	V	Hz	A	min ⁻¹	kW	μF/V	kg
DK 3/2	36	1300	230/400	50	5,0/2,9	2000	0,9	–	16,5
DK 3/2	34	1500	277/480	60	4,9/2,8	2780	1,2	–	16,5

50 Hz

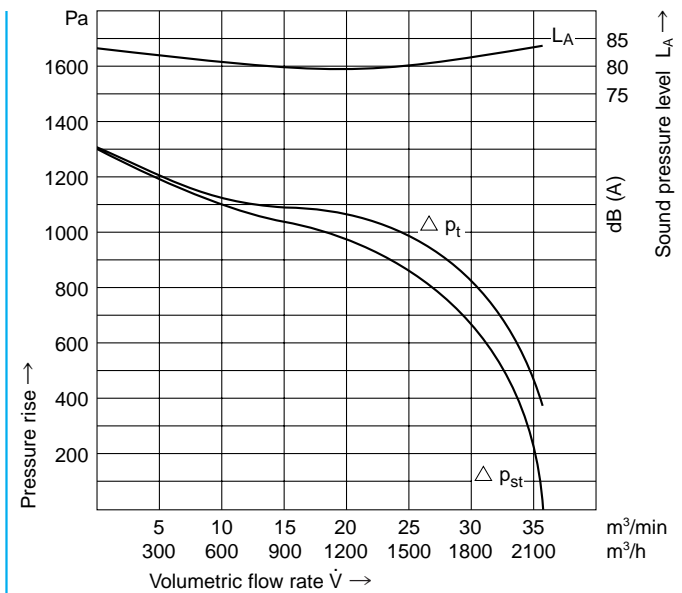

60 Hz

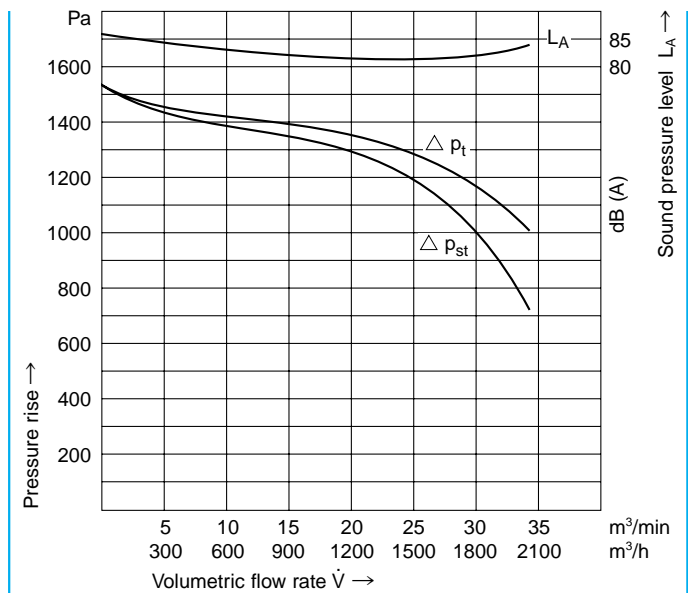

Blower not to be operated with free discharge.

Accessories

Throttle valve

for fitting on the blower discharge side

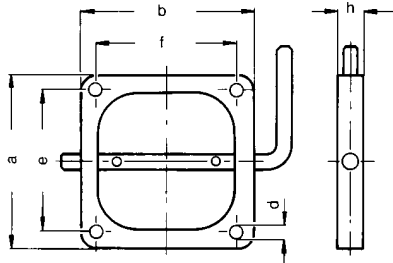

Blower type	a	b	d	e	f	h	No.	Code no.
E 02 SP	70	70	7	54	54	20	BST 286	0034
D 03, E 03	72	72	7	56	56	20	BST 287	0035
D 04, E 04 2D 04	76	76	7	64	64	20	BST 288	0095
D 05, E 05 2D 05	112	112	9	96	96	20	BST 289	0036
D 052, E 052 2D 052	130	130	7	105	115	20	BST 2553	0264
D 060, E 060 2D 060	140	140	9	115	115	20	BST 2706	1350
D 064, E 064 2D 064	150	130	9	130	110	20	BST 2097	0093
D 066, E 066	155	155	9	130	130	20	BST 2769	01129
D 07 D 072 2D 07	190	210	11	160	180	20	BST 2098	0094
D 08 D 082 2D 08	190	190	11	165	165	20	BST 2074	0106
D 09 D 092	220	220	11	196	196	20	BST 2264	0490

Discharge connector

for tube connection

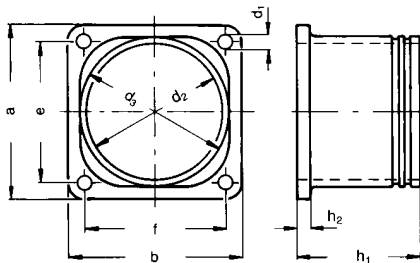

Blower type	a	b	d ₁	d ₂	d ₃	e	f	h ₁	h ₂	Part No.	Code No.
E 02 SP	70	70	7	46	54	54	54	70	5	10997	0043
D 03, E 03	72	72	7	52	60	56	56	70	5	10998	0044
D 04, E 04 2D 04	80	80	7	60	70	64	64	70	6	10999	0045
D 05, E 05 2D 05	112	112	9	86	96	96	96	100	8	2499	0046
D 052, E 052 2D 052	130	130	7	92	99	105	115	100	8	14830	0273
D 060, E 060 2D 060	140	140	9	110	120	115	115	100	10	15304	1351
D 064, E 064 2D 064	150	130	9	104	114	130	110	100	12	11640	0123
D 066, E 066	155	155	9	125	135	130	130	100	12	15934	01144
D 07 D 072 2D 07	190	210	11	150	160	160	180	120	12	2497	0048
D 08 D 082 2D 08	190	190	11	155	165	165	165	100	12	11639	0124
D 09 D 092	220	220	11	170	180	196	196	140	15	12357	0489

Intake connector

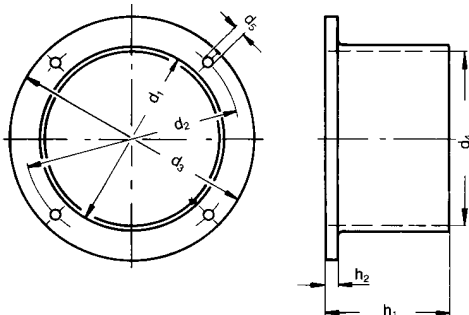

Blower type	d ₁	d ₂	d ₃	d ₄	d ₅	h ₁	h ₂	Part No.	Code No.
E 02 SP	on demand								
D 03, E 03	100	120	131	90,5	4×5,8	100	6	13728	0713
D 04, E 04 2D 04	120	140	151	110,5	4×5,8	100	6	12675	0714
D 05, E 05 2D 05	130	147	160	119,5	4×5,8	100	6	12674	0715
D 052, E 052 2D 052	151	171	180	140	4×5,8	100	6	14829	0254
D 060, E 060 2D 060	150	176	188	140	4×5,8	120	6	12673	0716
D 064, E 064 2D 064	160	198	210	149,5	4×5,8	140	6	12672	0717
D 066, E 066 D 07 D 072 2D 07	190	238	252	179	4×7	160	10	12687	0718
D 08 D 082 2D 08	220	256	272	208	4×7	160	10	12662	0719
D 09 D 092	250	290	310	234	8×7	180	10	12369	0488

Dimensions in mm – subject to modifications

Accessories

Fine filter

intake side

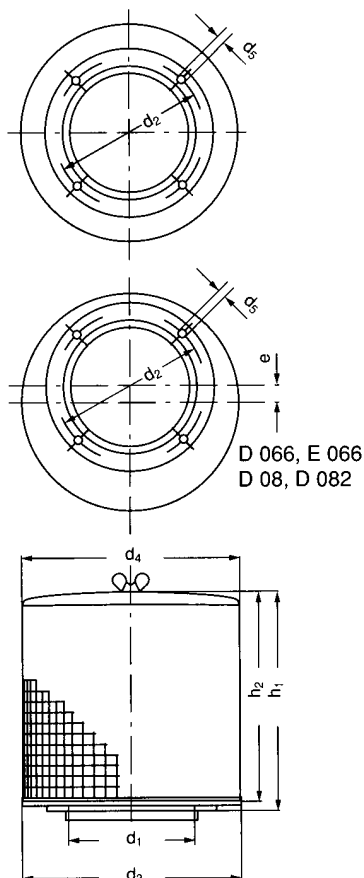

Layout and dimensions of Elektor fine filters are adapted to the maximum flow volume of the respective blowers and have a very small pressure loss therefore.

The filter surface has been selected for an air resistance of 50 Pa at an air flow velocity of q,5 m/s.

The insert filter tissue of synthetic fibres provides a high filtration efficiency of about 99 %.

Dirty filters may be cleaned with compressed air or by washing with a light soap lye.

All steel parts are zinc-galvanised to provide high corrosion protection

Caution

Clogged and dirty filters reduce the blower performance significantly. Cleaning of the filters in regular intervals is essential.

Blower type	d ₁	d ₂	d ₃	d ₄	d ₅	e	h ₁	h ₂	No.	Code-No.
E 02 SP	82	105	140	148	4×4,5	–	112	108	BST 2771	0420
D 03, E 03	95	120	140	148	4×5,5	–	116	108	BST 2381	0072
D 04, E 04 2D 04	106	140	202	210	4×5,5	–	133	126	BST 2366	0073
D 05, E 05 2D 05	116	147	202	210	4×5,5	–	245	238	BST 2367	0074
D 05, E 05 2D 05 verk. Ausf.	116	147	202	210	4×5,5	–	225	218	BST 2383	0564
D 052, E 052 2D 052	118	171	190	200	4×5,5	–	242	236	BST 2626	1227
D 060, E 060 2D 060	140	176	250	260	4×5,5	–	291	281	BST 2655	1262
D 064, E 064 2D 064	147	198	250	260	4×6	–	377	359	BST 2364	0076
D 066, E 066	222	238	315	315	4×7	24	471	453	BST 2770	01145
D 07 D 072 2D 07	180	238	310	315	4×7	–	479	460	BST 2378	0077
D 08 D 082 2D 08	240	256	410	410	4×7	40	474	456	BST 2527	0773
D 09 D 092	275	290	410	410	8×7	–	714	696	BST 2528	0774

Spare filter tissue

for fine filter

Blower type	Dimensions	Part No.	Code No.
E 02 SP	15×104×425	13 395	0423
D 03, E 03	15×104×425	13 395	0423
D 04, E 04 2D 04	15×120×620	13 301	0425
D 05, E 05 2D 05	15×230×620	13 236	0659
D 05, E 05 2D 05 verk. Ausf.	15×210×620	13 422	0691
D 052, E 052 2D 052	15×230×586	14 911	1228
D 060, E 060 2D 060	15×265×750	14 250	1263
D 064, E 064 2D 064	15×343×750	14 254	0666
D 066, E 066 D 07 D 072 2D 07	15×453×960	13 377	0692
D 08 D 082 2D 08	15×445×1220	14 262	0784
D 09 D 092	15×685×1220	14 268	0785

Dimensions in mm – subject to modifications

Accessories

Fine filter

intake side

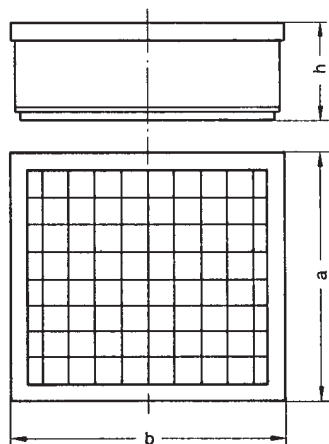

Blower type	a	b	h	No.	Code no.
DK 1/2, EK 1/2	235	259	80	BST2424	0430
DK 2/2 Rechtslauf DK 3/2	324	379	113	BST2443	0638
DK 2/2 Linkslauf DK 3/2	324	379	113	BST2540	075

Spare filter tissue

for fine filter

Blower type	Dimensions	Part no.	Code no.
DK 1/2, EK 1/2	15×225×250	13 435	0660
DK 2/2 DK 3/2	15×320×375	13 700	0608

Step switch 2 steps

with housing, enclosure IP 54
for three and single phase a.c.

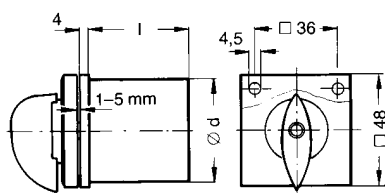

Blower type	Three phase a.c.			
	d	l	Part no.	Code no.
D 03 RS – D 072 RS	44	80	13 289	0622
D 082 RS, D 092 RS	50	100	13 719	0685

Step switch 2 steps

without housing, enclosure IP 00,
for three and single phase a.c.

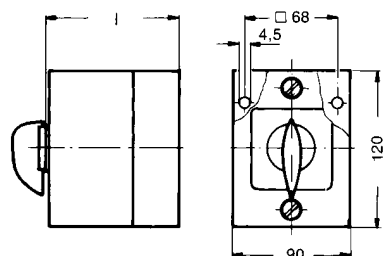

Blower type	Three phase a.c.		
	l	Part no.	Code no.
D 03 RS – D 072 RS	103	13 734	0711
D 082 RS, D 092 RS	103	13 735	0712

Dimensions in mm – subject to modifications