

Elektor Conveying Blowers

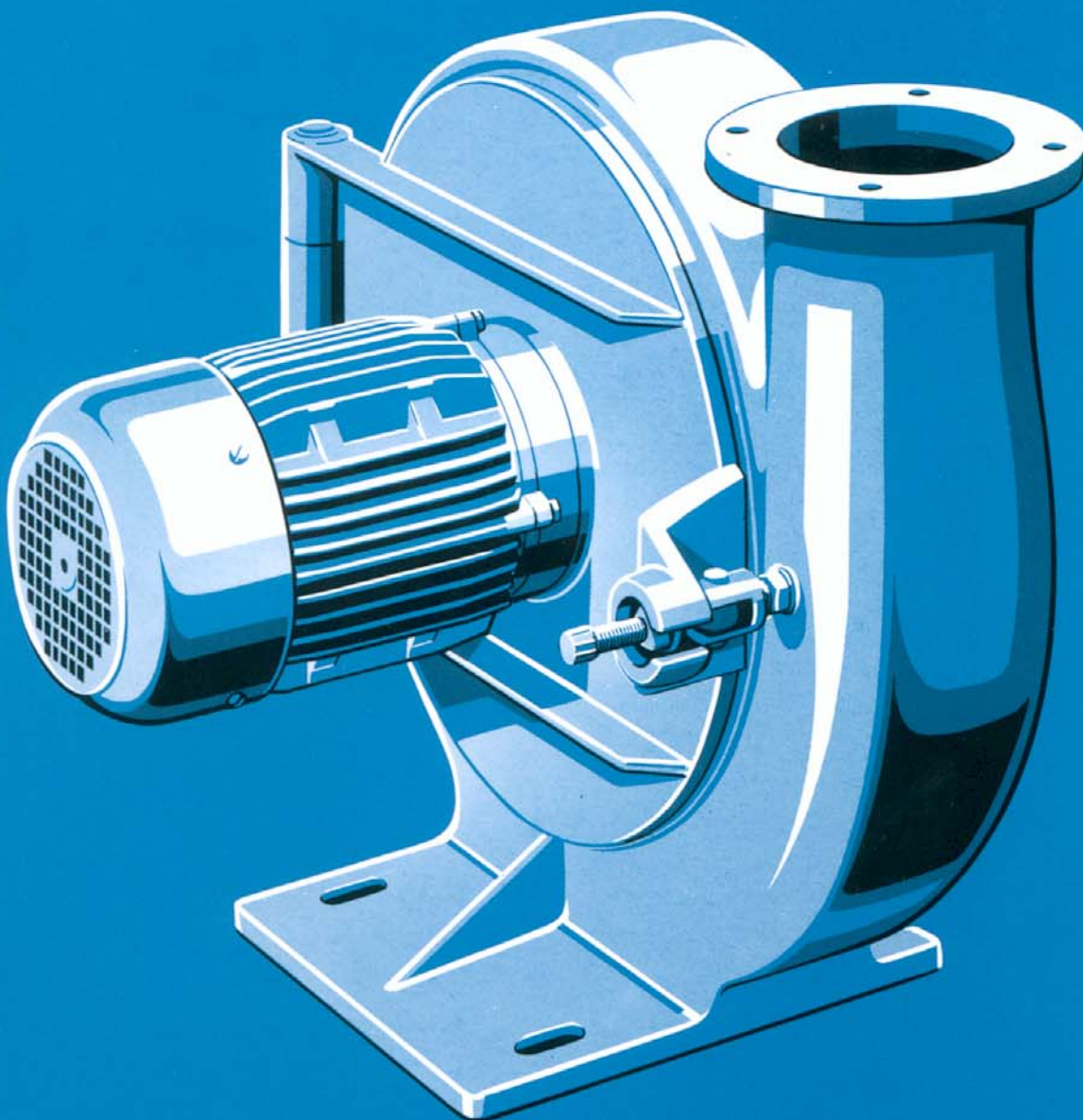

FD

Conveying Blowers

Elektor conveying or material handling blowers offer:

- High performance with compact design
- Ready-to-install design
- Favourable noise characteristics
- Sturdy abrasion-resistant design
- Conveying impeller of welded steel construction
- Long service life with low operating cost

Table of contents

1. Technical details	page 4
1.1 Design	page 4
1.2 Characteristics curves	page 4
1.3 Special designs	page 4
1.4 Directions for operation and maintenance	page 5
1.5 Safety	page 5
1.6 Ordering details	page 5
1.7 Remarks	page 5
2. Characteristic curves with dimensional drawings and technical data	page 6
3.1 Accessories	page 10
4. Summary of wider product range	page 12

Technical Details

1.1 Design

The FD range of Elektror conveying blowers come with welded sheet steel impellers with radial ending blades.

They are specially designed for the conveying of materials which may pass directly through the blower.

The blower housing and backplate are robustly made from cast iron which has abrasion-resistant qualities. The aerodynamic design and dynamically balanced impellers ensure vibration-free operation and low noise levels.

The conveying impeller is attached directly to the drive motor shaft. The motor itself is flange-mounted to the blower backplate which is hinged to the blower housing and can be opened for inspection and cleaning purposes. This can be done by loosening the central fixing nut by means of a special spanner.

All blowers can only be supplied in the pictured housing position.

All drive motors are made to IP 54 enclosure, class F thermal insulation, and comply with VDE 0530 (IEC 34-1). The motor power is oversized to have sufficient reserve for conveying materials and to ensure long and trouble-free operational life.

The standard motors are designed for a voltage of 230/400 V Δ/Y at a mains frequency of 50 Hz resp. for 400 V Δ in accordance with IEC 38. Motors for 60 Hz mains frequency are laid out for 277/480 V Δ/Y resp. 480 V Δ to IEC 38.

The conveying blowers correspond to the safety regulations and the technical requirements of the Supervisory Board of the Chemical Industry and have been tested and approved by this institution. We are therefore entitled to the safety emblem "GS" on our blowers and documentation. Test certificates of approved safety can be submitted on request.

1.2 Characteristic curves

The depicted characteristic curves of total pressure head Δp_t and of static pressure difference Δp_s , as function of the volumetric flow rate \dot{V} have been ascertained by tests without attaching the wire mesh guard on the intake port.

All measurements were taken on a pipe test bed to DIN 24 163 with throttling on the discharge side, and based on an air density of 1,2 kg/m³.

All pressures as well as the power consumption of the blowers vary in proportion to the density of the conveyed medium and are to be considered when selecting a blower.

Alterations in density due to influence of temperature are calculated as follows:

$$\rho_2 = \rho_1 \frac{273 + \delta_1}{273 + \delta_2} \quad \begin{matrix} \delta = \text{temperature of conveyed medium} \\ \rho = \text{air density} \end{matrix}$$

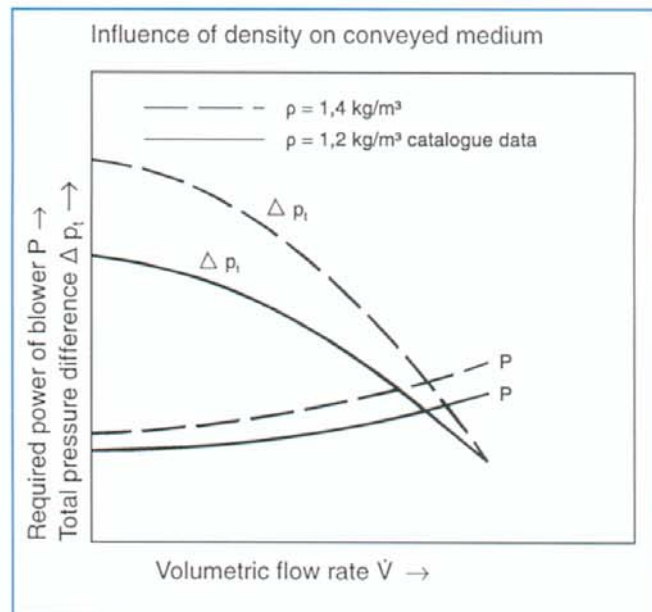

1.3 Special designs

Blowers with special voltage and frequency, multi-range windings, IP 55 enclosure, tropical and moisture-proof insulation, as well as full motor protection can be supplied on request.

For the conveying of light and non-abrasive bulk materials our RD range blowers can also be used. They will be equipped in this case with radial bladed conveying impellers made from welded sheet steel and will bear the denomination RD 74 F for instance.

Inspection and cleaning may only be carried out by unscrewing the housing cover plate of these units.

1.4 Directions for operation and maintenance

Elektor conveying blowers are suitable for the conveying of plastic granules and plastic waste as well as all kind of light bulk materials.

Materials or mixtures which may prove dangerous under operation, cannot be conveyed, as for instance combustible dusts, explosive materials, unstable chemical substances or mixed substances which may react with each other.

The units are to be installed in weather-protected places and must not be exposed to stress by vibrations and shocks. Units above 3 kW have to be started in Y/Δ configuration. Adequate motor cooling is essential. Maximum cooling air temperature for the motor is 40 °C; permitted temperature for the conveyed medium ranges from -15 °C up to +60 °C.

Conveying blowers succumb to attrition and depending on the nature of the conveyed material they have to be checked periodically. Wear and tear parts, such as the conveying impeller, have to be replaced in due time as irregular wear may cause a serious unbalance which results in bearing failure.

To clean or replace the impeller, swivel the hinged motor backplate with the impeller out of the blower housing. Before attempting any repair work, be certain that all power to the motor and electrical accessories is cut off.

Maintenance work on the motor is not necessary because they are fitted with sealed grooved ball bearings which do not need relubrication during their whole service life.

For maintenance and repair work use original spare parts only. They are listed in the spare parts list included in the delivery.

1.5 Safety

Cleaning and repair work on the conveying blower are only permitted after complete standstill of the impeller.

ON/OFF switches must be locked or in a position where motor starting during cleaning and repair work is impossible.

If the conveying blower is operated for blowing or extracting only (no pipe or duct work connected on the intake or outlet side) a contact protection device according to DIN 31 001 part 1 has to be fitted to the open port.

This protection device must be ordered additionally.

1.6 Ordering details

Blower type

Flow volume

Required total pressure rise or static pressure difference

Voltage, frequency, three or single phase a.c.

Ambient and conveyed medium temperature

Nature of conveyed medium

Accessories, special requirements

1.7 Remarks

Dimensions, technical data and descriptions are approximate only. They are subject to modifications and errors.

FD 62

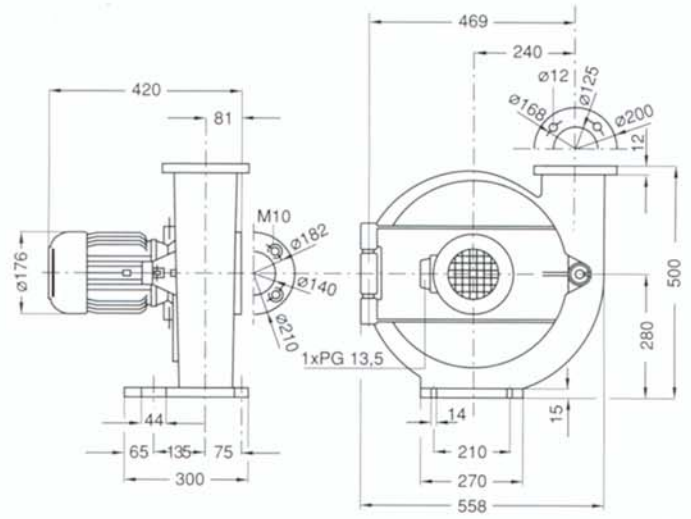

Dimensions in mm. Subject to modifications.

Type	Volumetric flow rate	Total pressure difference	Voltage	Frequency	Current absorption	Number of revolutions	Motor rating	Weight
	m ³ /min	Pa	V	Hz	A	min ⁻¹	kW	kg
FD 62	25	1900	230/400	50	7,5/4,3	2830	1,8	79
FD 62	25	1900	277/480	60	7,4/4,3	3420	2,2	79

50 Hz

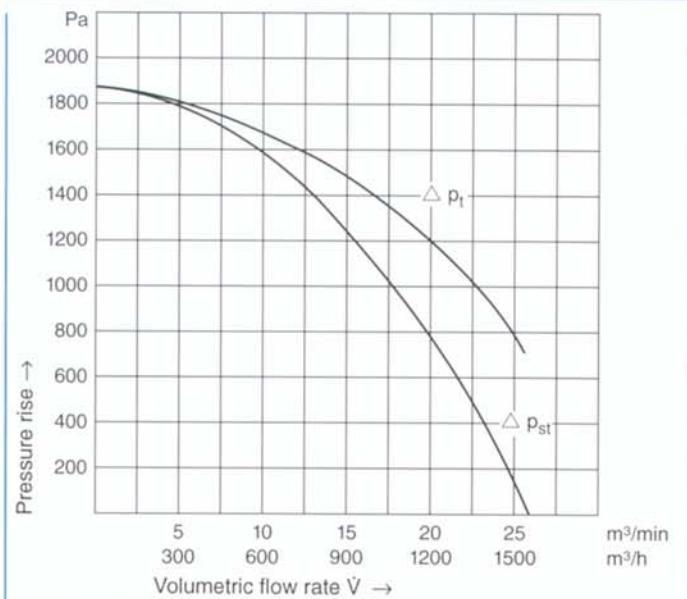

60 Hz

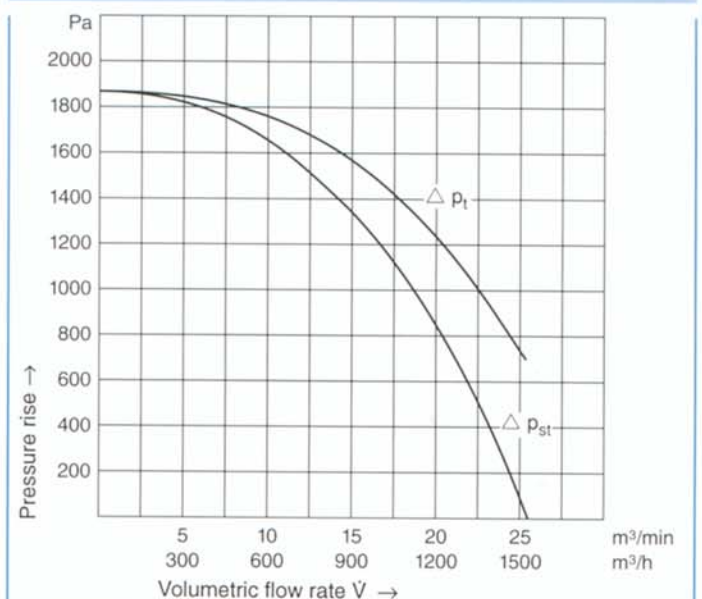

FD 64

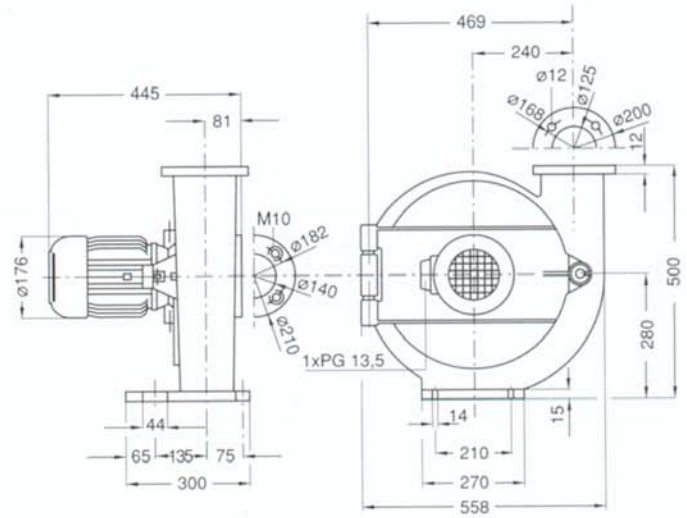

Dimensions in mm. Subject to modifications.

Type	Volumetric flow rate	Total pressure difference	Voltage	Frequency	Current absorption	Number of revolutions	Motor rating	Weight
	m ³ /min	Pa	V	Hz	A	min ⁻¹	kW	kg
FD 64	30	2200	230/400	50	10,0/5,8	2860	2,6	82
FD 64	30	2200	277/480	60	10,4/6,0	3460	2,8	82

50 Hz

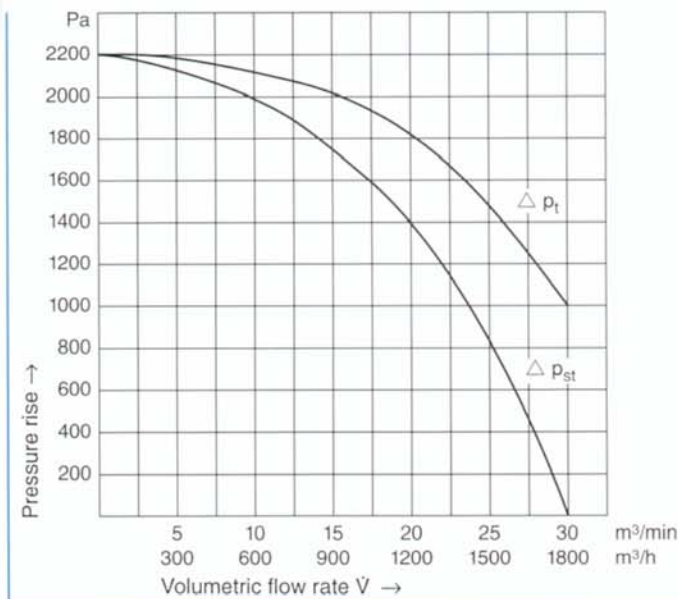

60 Hz

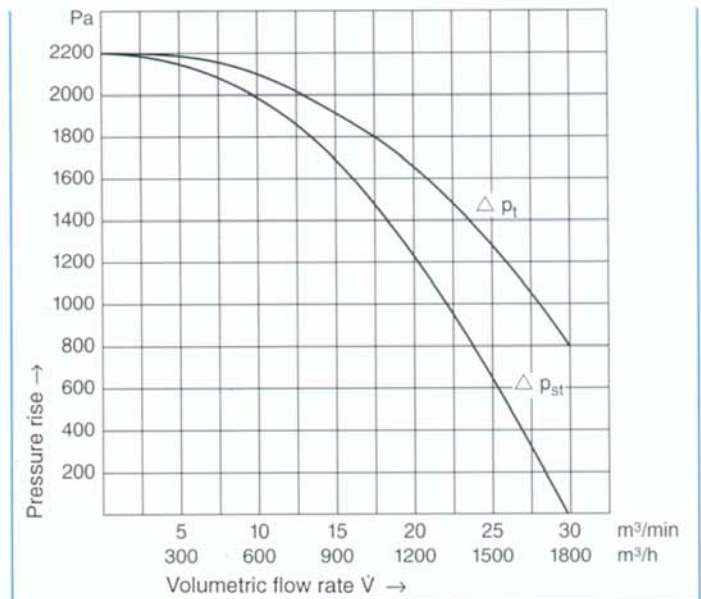

FD 72

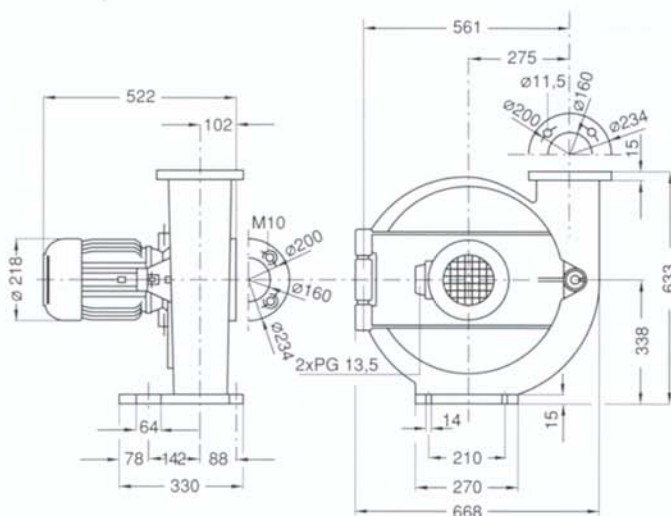
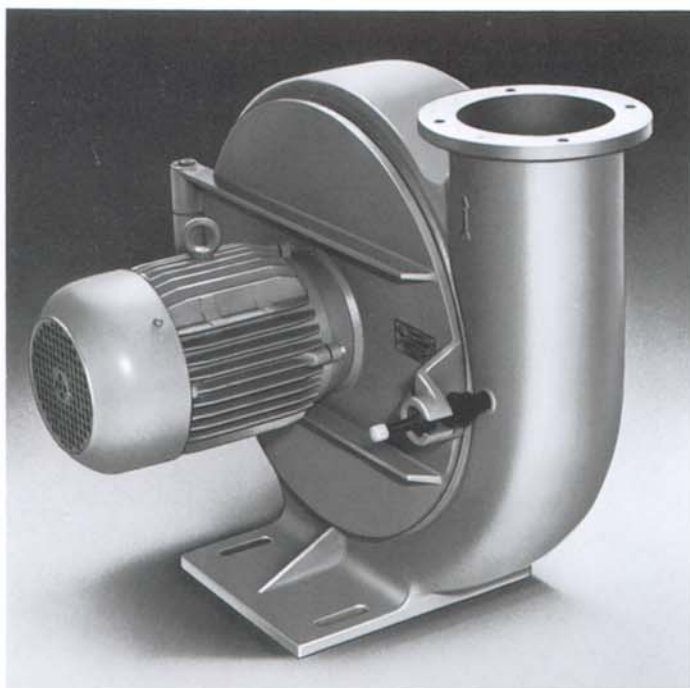

Dimensions in mm. Subject to modifications.

Type	Volumetric flow rate	Total pressure difference	Voltage	Frequency	Current absorption	Number of revolutions	Motor rating	Weight
	m ³ /min	Pa	V	Hz	A	min ⁻¹	kW	kg
FD 72	50	3400	400 Δ	50	9,6	2900	4,3	113
FD 72	50	3700	480 Δ	60	8,3	3500	4,4	113

50 Hz

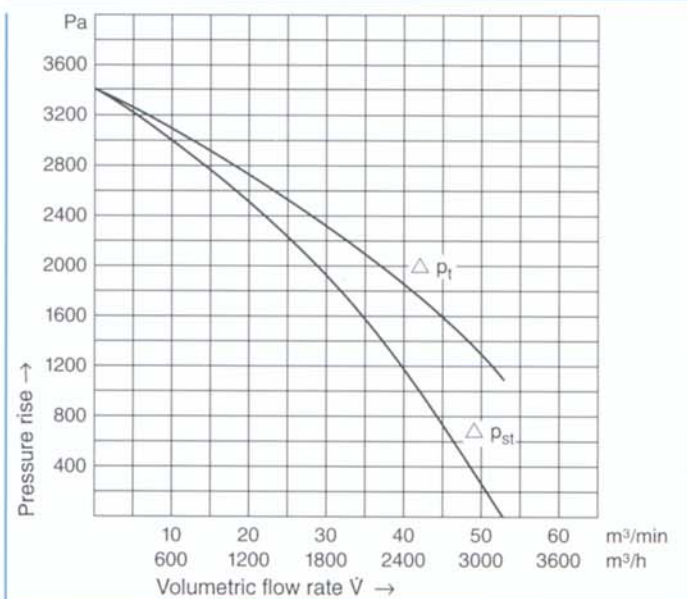

60 Hz

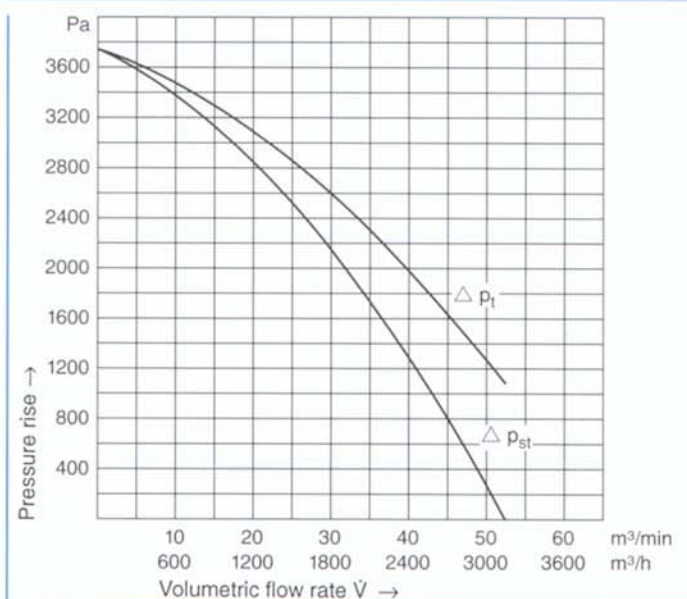

FD 74

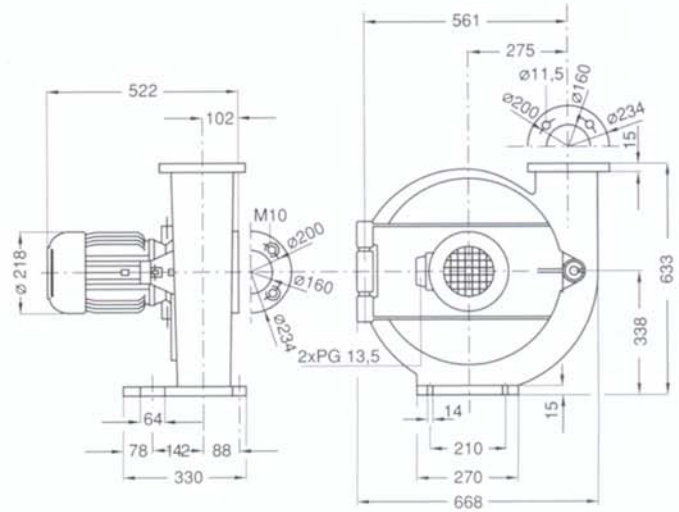

Dimensions in mm. Subject to modifications.

Type	Volumetric flow rate	Total pressure difference	Voltage	Frequency	Current absorption	Number of revolutions	Motor rating	Weight
	m ³ /min	Pa	V	Hz	A	min ⁻¹	kW	kg
FD 74	60	3900	400 Δ	50	13,0	2900	6,0	117
FD 74	60	4000	480 Δ	60	12,6	3500	7,0	117

50 Hz

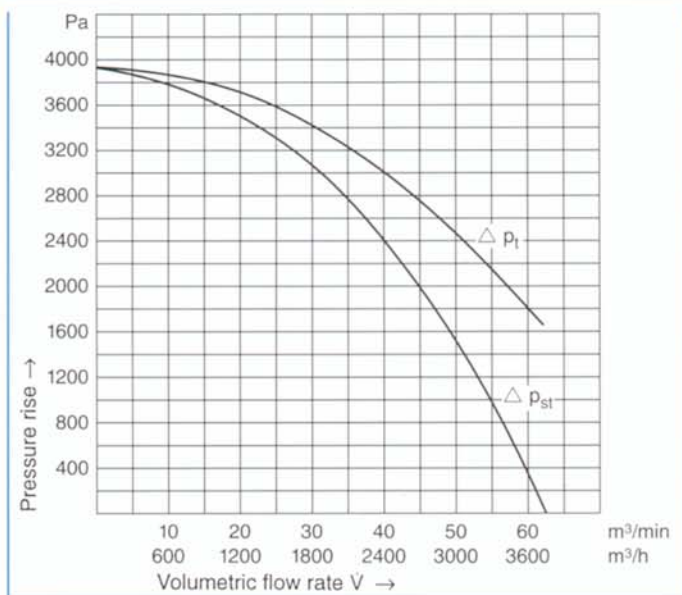

60 Hz

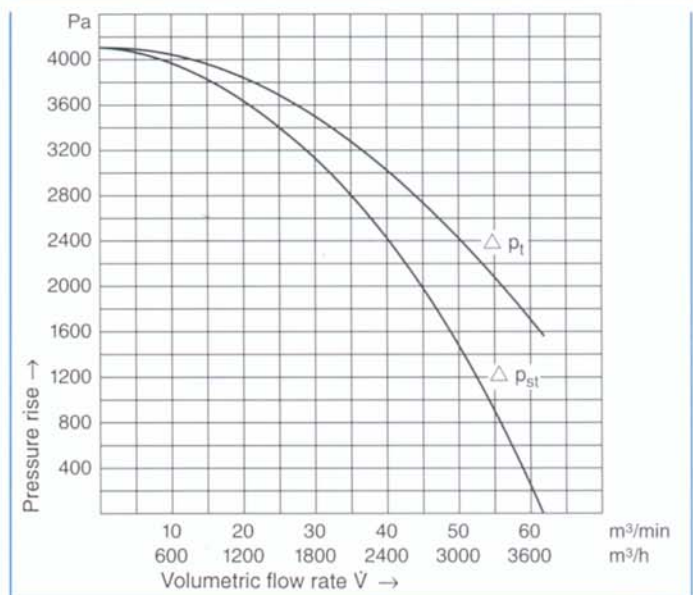

Accessories

Intake connector

for tube connection

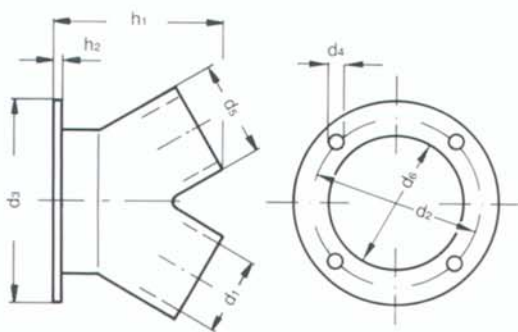
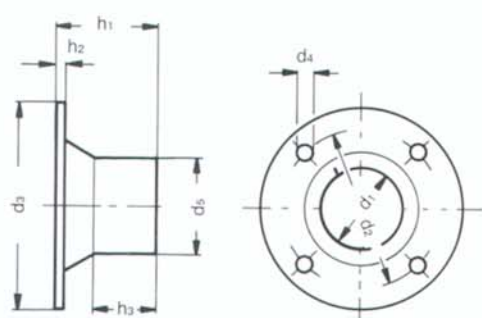
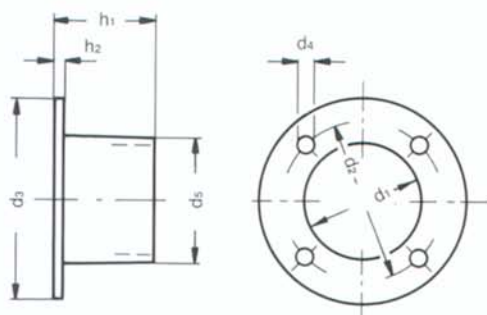

Blower type	d ₁	d ₂	d ₃	d ₄	d ₅	h ₁	h ₂	Part no.	Code no.
FD 62 FD 64	140	182	210	11	154	100	6	14407	1177
FD 72 FD 74	160	200	234	11,5	174	100	12	14343	0504

Blower type	d ₁	d ₂	d ₃	d ₄	d ₅	h ₁	h ₂	h ₃	Part no.	Code no.
FD 62 FD 64	88	182	210	11	100	100	6	66	14201	0766
FD 72 FD 74	86	200	234	11,5	98	100	12	66	14515	0312

Blower type	d ₁	d ₂	d ₃	d ₄	d ₅	d ₆	h ₁	h ₂	Part no.	Code no.
FD 62 FD 64	88	182	210	11	99	140	178	6	14301	0502
FD 72 FD 74	88	200	234	11,5	98	160	178	8	14782	0325

Dimensions in mm. Subject to modifications.

Accessories

Discharge connector

for tube connection

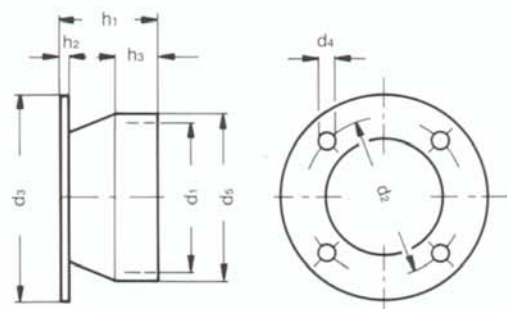
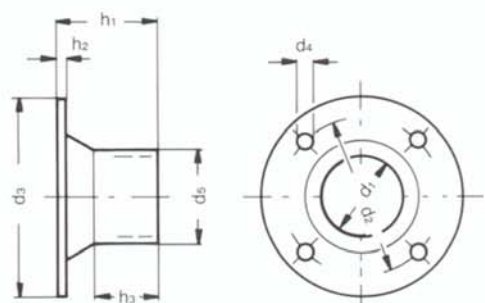
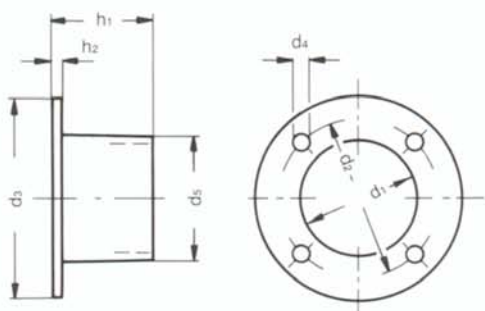

Blower type	d_1	d_2	d_3	d_4	d_5	h_1	h_2	Part no.	Code no.
FD 62 FD 64	125	168	200	11	139	100	6	14408	1178
FD 72 FD 74	160	200	234	11,5	174	100	12	14343	0564

Blower type	d_1	d_2	d_3	d_4	d_5	h_1	h_2	h_3	Part no.	Code no.
FD 62 FD 64	88	168	200	11	100	100	6	68	14202	0767
FD 72 FD 74	86	200	234	11,5	98	100	12	66	14515	0313

Blower type	d_1	d_2	d_3	d_4	d_5	h_1	h_2	h_3	Part no.	Code no.
FD 62 FD 64	163	168	200	11	174	100	6	45	14300	0495

Dimensions in mm. Subject to modifications.

Product range

Low pressure blowers	catalogue ND
Medium pressure blowers	catalogue MD
Medium pressure blowers, reduced noise level range	catalogue RD
High pressure blowers	catalogue HDn
High pressure blowers, reduced noise level range	catalogue HRD
Side channel blowers	catalogue SD
Conveying blowers	catalogue FD
Vibrating motors	catalogue VM
Alarm sirens	
Aluminium sand castings	
Aluminium die castings	

Elektor

KARL W. MÜLLER GMBH & CO.

P. O. Box 100251

D-73702 Esslingen/Neckar

Richard-Hirschmann-Strasse 12

D-73702 Esslingen/Neckar

Phone: +49 (0) 711 31973-0

Fax: +49 (0) 711 31973-176

Internet: <http://www.Elektor.de>

E-Mail: info@Elektor.de